

# ***“LEADERS IN LIGHTING TECHNOLOGY”***

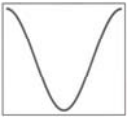

24 Ashfield Avenue, Springfield Park, Durban, South Africa  
Telephone: +27 31 5792172/3/5 Fax: +27 31 5792176  
PO Box 10177, Marine Parade, 4056, South Africa  
e-mail : [admin@cosine.co.za](mailto:admin@cosine.co.za) / Web site : [www.cosine.co.za](http://www.cosine.co.za)

Due to continuous product improvement colour, sizes, materials, finishes and specifications are subject to change without notice. Consult manufacturer for latest specifications. All manufacturing rights reserved. This document is for information only and shall not form part of any contract.



## TABLE OF CONTENTS

1.	<b>INTRODUCTION</b>	4
2.	<b>EMERGENCY CONTROL GEAR</b>	4
2.1	<b>STANDARD RANGE</b>	
2.1.1	<b>TLX RANGE</b> <i>Standard emergency control unit for fluorescent lamps</i>	9
2.1.2	<b>TL40/TL65 RANGE</b> <i>High light output emergency control units</i>	13
2.1.3	<b>HPLD</b> <i>High light output emergency control units</i>	16
2.1.4	<b>TLX_STBY/E</b> <i>Emergency control unit with standby feature</i>	17
2.1.5	<b>PLX</b> <i>Emergency control unit for 2 pin CFL's</i>	19
2.1.6	<b>PLX - SUPERNOVA (100%)</b> <i>Light Emergency control unit for 2 pin CFL's</i>	22
2.1.7	<b>AMALGAM</b> <i>Emergency control unit for triple turn PLT 4 pin lamps</i>	24
2.1.8	<b>ELG-85M</b> <i>Emergency lighting gear for 60/85W CFL's</i>	25
2.2	<b>SELF TEST RANGE</b>	
2.2.1	<b>THX</b> <i>Self testing emergency control</i>	28
2.2.2	<b>THX WATCH</b> <i>Self testing emergency control unit with optional central display</i>	31
2.2.3	<b>THX_IR</b> <i>Infra-red remote controlled self testing emergency control unit</i>	33
2.2.4	<b>ELS Self test</b> <i>self testing emergency control unit</i>	37
2.2.5	<b>THX SUPERNOVA</b> <i>2-pin self testing emergency control unit</i>	39
2.3	<b>DOMESTIC RANGE</b>	
2.3.1	<b>ELS 12 Volt</b> <i>emergency lighting system for halogen lamps or luminaires</i>	42
2.3.2	<b>PANTHER</b> <i>Emergency Light</i>	44
2.4	<b>HIGH RISK AREAS RANGE</b>	
2.4.1	<b>ELS_SPOT</b> <i>Emergency control unit with two 20W halogen spot lamps</i>	47
2.4.2	<b>ELS_BIG BEAM</b> <i>Emergency control unit with two 50W halogen lamps</i>	48
2.4.3	<b>ELS_MINI WEDGE</b> <i>Emergency control unit with a fluorescent floodlight</i>	49
2.4.4	<b>ELS_NICAD</b> <i>Emergency control gear for low voltage down-lights</i>	50
2.4.5	<b>ELS HP</b> <i>Three hour emergency spot-light unit</i>	51
2.5	<b>INTELLIGENT RANGE</b>	
2.5.1	<b>INTELLITE</b> <i>Self testing emergency spot light with remote control</i>	53
2.6	<b>CENTRAL BATTERY SYSTEM RANGE</b>	56
2.6.1	<b>CENTRAL BATTERY SYSTEM</b> <i>Centralised emergency lighting</i>	57
3.	<b>BATTERIES</b>	
3.1	<b>BATTERIES</b> <i>Battery packs for emergency lighting</i>	62
4.	<b>INVERTERS</b>	63
4.1	<b>TL12/24/48Vdc</b> <i>Fluorescent lamp inverters for dc supplies</i>	64
4.2	<b>TL12Vdc/2</b> <i>Dual fluorescent lamp inverter for 12V dc supplies</i>	65
4.3	<b>TL20/40_24Vdc</b> <i>Fluorescent lamp inverters for railway coach lighting</i>	66
4.4	<b>TL20_75/110Vdc</b> <i>Fluorescent lamp inverters for high dc voltages</i>	67
4.5	<b>TL24Vac</b> <i>Fluorescent lamp inverter for 24V ac supply voltage</i>	68
4.6	<b>TL32Vac</b> <i>Fluorescent lamp inverter for 32V ac supply voltage</i>	68
4.7	<b>TL32Vac-SUPREME</b> <i>42W CFL inverter for 32V ac supply voltage</i>	69
5.	<b>ELECTRONIC BALLASTS</b>	
5.1	<b>Electronic ballasts</b>	70
6.	<b>LIGHT CONTROLLERS</b>	
	<b>PHOTOCELLS</b>	
6.1	<b>DN1</b> <i>Day/Night switch – heavy duty</i>	72
6.2	<b>DN2..DN2-L</b> <i>Day/Night switch – CFL loading</i>	74
6.3	<b>DN-3</b> <i>Day/Night switch – 125W loading</i>	75

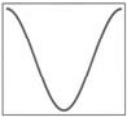

# COSINE DEVELOPMENTS

“LEADERS IN LIGHTING TECHNOLOGY”

---

## OCCUPANCY MANAGEMENT SYSTEMS

6.4 **INFRA-RED AUTO SWITCH** *Occupancy Sensor for Energy Saving* 77

6.5 **MICROWAVE SENSOR** *micro wave sensor for energy saving* 79

## BOLLARD

7.1 **Bollard** *emergency light* 80

## LED LIGHTING

8.1 **LED RANGE** *LED emergency lighting* 81

## BOLLARD

9.1 **SOLAR RANGE** *Solar powered lighting* 82

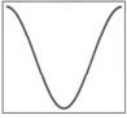

## 1. INTRODUCTION



**COSINE DEVELOPMENTS**, part of the **RML Lighting Group**, was established in 1997 to develop lighting related electronics. Research and development capabilities have ensured our position as leaders in emergency lighting and fluorescent lamp inverters. All products are designed to meet the stringent South African Bureau of Standards (SABS) requirements in terms of performance, reliability and safety (SABS Standards are based on international IEC Standards).

A comprehensive range of emergency control gear will satisfy most industrial and commercial requirements. Products include:

- Basic industrial one hour and three hour control units for fluorescent lamps.
- Emergency control units for halogen lamps.
- A domestic emergency lighting system.
- Self testing emergency control units for both fluorescent and halogen lamps.
- A central battery emergency control system.
- A self testing emergency control system with central indication and BMS link.
- Infra-red controlled emergency control units

A large range of fluorescent lamp inverters operating from 12, 24, 36, 48 and 110 V dc capable of driving lamps from 8 to 65 Watts have been designed to provide long lamp life and high reliability. Products satisfy IEC Standards 924, 925 and 60081.

A solar lighting system has been especially developed to provide a single low cost dwelling with lighting at an affordable cost.

Developments include research into the performance and requirements of new technology lamps such as T5 and PLT fluorescents, LED's as well as lamp life considerations.

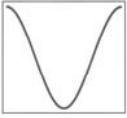

## 2. EMERGENCY CONTROL GEAR

### 2.1 STANDARD RANGE

#### 2.1.1 TLX RANGE

- TLX3/1hr Emergency control unit for fluorescent lamps – 36W
- TLX3/3hr/T Emergency control unit for fluorescent lamps – 36W
- TLX5/1hr Emergency control unit for fluorescent lamps – 65W
- TLX5/1hr/E Emergency control unit for fluorescent lamps – 65W
- TLX5/1hr/E Slim-Line Emergency control unit for fluorescent lamps – 54W
- TLX5/3hr/T Emergency control unit for fluorescent lamps – 65W
- TLX5/3hr/T/E Emergency control unit for fluorescent lamps – 65W

#### 2.1.2 TL40/65 RANGE

##### TL40 Range – 50%

- TL40\_50% High light output emergency control unit
- TL40\_1/E (50%) High light output for electronic ballasts

##### TL65 Range – 50%

- TL65\_50% High light output emergency control unit
- TL65\_1/E (50%) High light output for electronic ballasts

##### TL40 Range HO

- TL40\_100% High light output emergency control unit
- TL40\_1/E (100%) High light output for electronic ballasts

##### TL65 Range HO

- TL65\_100% High light output emergency control unit
- TL65\_1/E (100%) High light output for electronic ballasts

2.1.3 **TLX\_STBY/E** Emergency control unit with standby feature

2.1.4 **PLX** Emergency control unit for 2 pin Compact Fluorescent Lamps

2.1.5 **PLX-SUPERNOVA** 100% Light Output Emergency control unit for 2 pin Compact Fluorescent Lamps

2.1.6 **AMALGAM** Emergency control unit for triple turn PLT 4 pin lamps

2.1.7 **ELG-85M** Emergency Lighting Gear for 60/85W Compact Fluorescents

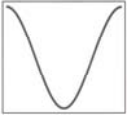

## LEGAL REQUIREMENTS

The **Occupational Health and Safety Act (Act 85 of 1993)** requires emergency evacuation lighting for workplaces without natural light. It is therefore illegal not to have emergency evacuation lighting in work areas or public places where no natural light is present. A minimum of 0.3 lux at the floor level is required to enable evacuation but a level of not less than 20 lux is required for moving machinery or where it is necessary to shut down plant or processes where dangerous materials are present. The act also requires that the emergency lighting must be activated within 15 seconds and the emergency lighting must be kept in good working order and tested at intervals of not more than three months.

All emergency lighting must comply with the following requirements of **SABS 1464 Part 22**:

- **Classification:** Emergency luminaires shall have labelling to indicate whether they are self contained or centrally supplied, maintained or non-maintained, have test devices and emergency duration. The following symbols shall be used: **X** = self-contained, **Z** = central supply, **0** = non-maintained, **1** = maintained, **6** = satellite, **A** = including test devices, **B** = including remote rest mode, **C** = including inhibiting mode, **D** = high risk task area lighting, **10** = ten minutes duration, **60** = one hour duration, **120** = two hours duration, **180** = three hours duration.
- **Marking:** Luminaires shall be clearly marked with rated voltage, correct replacement lamps and maximum ambient temperature. Emergency lamp holders in combined luminaires shall be identified by a green dot. A label on the battery pack shall indicate replacement battery details, battery manufacture and commissioning date.
- **An instruction leaflet** shall be provided detailing test facilities and test procedures.
- **Electrical safety:** Requirements of SABS 598-1 shall apply.
- **Endurance and thermal testing:** The unit must satisfy various soak and cycle testing to ensure reliability.
- **Battery charge and discharge:** The batteries must be charged within 24 hours, deep battery discharge must be prevented and high temperature batteries must be used in self contained emergency luminaires.
- **Photometric performance:** The luminaire shall provide rated lumen output claimed by the manufacturer during emergency mode for 1 minute after failure of supply and continuously to the end of rated duration. In other words, if the unit is marked as a 50% light output then the emergency light output must be 50% of the mains light output.

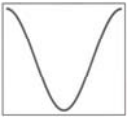

---

## GLOSSARY OF DEFINITIONS

**BMS:** Building Management System.

**Centrally supplied luminaire:** A luminaire (for maintained or non-maintained operation) energised from a central emergency power supply.

**ECG:** High frequency electronic control gear to drive the fluorescent lamp from the mains supply.

**Emergency control unit:** An electronic module usually fitted inside the luminaire that enables the lamp to operate from mains during normal conditions and powers the lamp from a battery pack (usually at low brightness) in the event of a power failure.

**Emergency lighting duration:** The emergency lighting provided during a power failure. It is important to note that this minimum figure should be comfortably exceeded during initial testing to compensate for battery ageing.

**Fluorescent lamp inverter:** An electronic module that power a fluorescent lamp at full brightness from a dc supply.

**High-risk task area lighting:** provides illumination for the safety of people involved in a potentially dangerous process or situation that enables proper shut-down procedures.

**Maintained lighting system:** An emergency lighting system requires two mains feeds: a permanent live connection and a switched live connection. The luminaire may be switched on and off with a healthy mains supply and the emergency control unit energises the lamp during a mains failure. The advantage of this system is that the luminaire can be used to provide normal lighting but the disadvantage is that the luminaire requires additional wiring.

**Non-maintained lighting system:** An emergency lighting system requires a single permanent mains supply. The luminaire cannot be used to provide normal lighting. In the event of a power failure the emergency control unit energises the lamp. The advantage of this system is that the lamp is not aged during normal mains conditions but the disadvantage is that the luminaire cannot provide normal lighting.

**Self testing control unit:** An emergency control unit that automatically conducts regular tests to establish the condition of the lamp and battery pack.

**Stand-by lighting:** Non-mandatory emergency lighting that is provided to enable normal activities to continue substantially unchanged.

**Sustained lighting system:** An emergency lighting system requires a single permanent mains connection. The fluorescent lamp is permanently energised from the mains supply and is powered by the emergency control unit during a power failure. The advantages of this system are that one live feed is required and the luminaire can provide normal lighting. The disadvantage is that the luminaire must remain on permanently.

**Switch start ballast:** A conventional inductive ballast and glow starter system. This system is being phased out due to its poor efficiency.

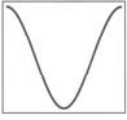

---

## **INSTALLATION AND MAINTENANCE GUIDE**

### **EMERGENCY GEAR INSTALLATION**

Both the emergency control unit and the batteries are adversely affected by high temperatures. It is therefore essential that these components are fitted in the coolest region of the luminaire. The worst offenders are usually maintained bulkhead luminaires (mostly used in stairwells) where the high temperatures inside the fitting destroy the batteries within weeks. The following tips will ensure optimum performance of the emergency gear:

- Mount the emergency gear as far as possible away from the ballast.
- Secure both the emergency control unit and batteries with bolts and nuts (not adhesives) to allow for easy replacement.
- Position the indicator lamp so that it will be visible at ground level when the luminaire is switched on (light from the luminaire should not swamp the light from the indicating lamp).
- Keep wiring as short as possible (maximum wire length is three metres).
- Affix the necessary labels in accordance with SABS 1464 Part 22.
- Connect battery to control unit and test with mains.
- Disconnect battery pack.
- The battery pack should not be reconnected until the building wiring is complete. If the emergency unit is switched on and off repeatedly during this phase then damage to both the batteries and lamp may result.
- A permanent live feed must be routed to all emergency luminaires. This is essential because if the units are switched off every night and the units switch over to emergency lighting then both the batteries and lamps will deteriorate rapidly.

### **EMERGENCY GEAR MAINTENANCE**

In order to ensure that your emergency lighting will function in the event of a power failure it is important to conduct regular tests.

- Emergency lighting should be tested at least once per month by turning off the main circuit breaker for a few minutes. Emergency luminaires should be identifiable in accordance with SABS 1464 Part 22.
- Do not merely turn off the permanent live feed to the emergency luminaires without switching off the switched live feed if electronic control gear (electronic ballasts) is used. This may result in the electronic control gear shutting down and require resetting.
- Periodically check the commissioning date on the battery packs. If the battery packs are older than three years then they should be replaced.
- Periodically inspect the emergency lamps to ensure that end blackening is not excessive and replace if necessary.
- If self testing emergency control gear is used then no testing is required. Visual inspections of indicating lamps are only needed to ascertain system status.

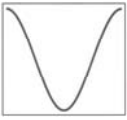

## 2.1.1 TLX RANGE *Standard emergency control unit for fluorescent lamps*



The TLX range of emergency control units cover all axial fluorescent lamps as well as four pin compact types from 6 to 65 Watts. The following versions provide an emergency lighting duration of either one or three hours:

VERSION	BALLAST TYPES	DURATION	BATTERY PACK (Ni-cad)	FLUORESCENT LAMPS
TLX3/1hr	Switch start	One hour	3 x 2 Ahr cells	Up to 36 Watts
TLX5/1hr	Switch start	One hour	5 x 2 Ahr cells	Up to 65 Watts
TLX5/1hr/E	All	One hour	5 x 2 Ahr cells	Up to 80 Watts
TLX3/3hr/T	Switch start	Three hours	3 x 4 Ahr cells	Up to 36 Watts
TLX5/3hr/T	Switch start	Three hours	5 x 4 Ahr cells	Up to 65 Watts
TLX5/3hr/T/E	All	Three hours	5 x 4 Ahr cells	Up to 80 Watts

The units comply with BS EN 60598-2-22, BS EN 60924 and SABS 1464: Part 22. Either maintained or non-maintained mode can be used. A safety start circuit is provided that prevents emergency operation until mains is connected. This enables installation without disconnecting or depleting the batteries. A red light indicates that the batteries are being charged. The unit is housed in a high quality glass sphere reinforced polyamide polymer. This material has excellent high heat resistance and impact strength properties. The emergency light output is sufficient to satisfy most escape route and anti-panic area lighting requirements. The unit can be used with conventional switch start, electronic or dimming ballasts.

**Note 1:** The emergency lighting duration and light output may vary due to ambient temperature, cell type and lamp manufacturer.

**Note 2:** The unit may be provided for operation from 110Vac.

Units also available with a photocell option.

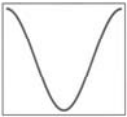

# COSINE DEVELOPMENTS

“LEADERS IN LIGHTING TECHNOLOGY”

**SPECIFICATIONS:** (parenthesis = 3 hour versions)

Mains voltage tolerance	230Vac +/- 10% 50 Hz
Lamp types	7 to □80 Watt fluorescent lamps
Emergency lighting duration	(3 hours) 1 hour
Mains power consumption	2VA
Battery discharge current	1 A
Deep discharge protection	> 0.8V/cell
Charging current	(200 mA) 100 mA
Charging indication	provided
Quiescent current	< 1 μA
Battery short circuit tolerance	indefinite
Controller (L x W x H):	171 x 45 x 35mm
Battery:	3.6 – 6V ni-cad
Weight	158g (242g)
Maximum operating temperature	+70 C

The table shows the performance of the units with various lamps (parenthesis = 3 hour units):

LAMP TYPE	LIGHT OUTPUT	BATTERY CURRENT	DURATION
T12: 65W	11% (9%)	1.3A (1A)	1.4 (4) hours
T8 : 58W	12% (11%)	1.3A (1A)	1.4 (4) hours
T12 : 40 W	15% (13%)	1.2A (0.8A)	1.5 (4.7) hours
T8 : 36W	18% (15%)	1.1A (0.9A)	1.6 (4.4) hours
T12 : 20 W	19% (17%)	0.6A (0.6A)	3 (6.8) hours
T8 : 18W	20% (22%)	0.7A (0.7A)	2.6 (6.1) hours
T8 : 10W	30% (32%)	0.6A (0.5A)	3 (8) hours
T5 : 8W	40% (45%)	0.7A (0.6A)	2.6 (6.8) hours
TC-DEL: 26W	32% (18%)	1.2A (0.8A)	1.5 (4.7) hours
TC-DEL: 18W	29% (26%)	1A (0.8A)	1.8 (4.7) hours
TC-DEL: 13W	36% (30%)	1A (0.6A)	1.8 (6.8) hours
TC-DD : 28W	25% (15%)	1.2A (0.7A)	1.5 (6.1) hours
TC-L : 18W	23% (19%)	0.7A (0.6A)	2.6 (6.8) hours
TC-EL : 11W	43% (42%)	0.9A (0.6A)	2 (6.8) hours
TC-EL : 9W	36% (31%)	0.6A (0.5A)	3 (8) hours
TC-EL : 7W	38% (44%)	0.7A (0.5A)	2.6 (8) hours

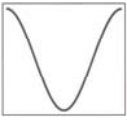

## TLX5/1hr/E/T-Slim -Emergency Control Unit (Slim-Line)



- Slim-Line version of Standard TLX5/1hr/E/T Emergency Controller
- Designed specifically for T5 bulkheads
- Low profile housing i.e. W=30mm x H=30mm
- 1 hour Emergency light
- Low Battery discharge protection
- Reverse battery protection
- Maintained or non-maintained
- Drives 8 to 80W lamps i.e. linear and CFL's
- Designed, developed and manufactured in South Africa
- Suitable for switch start and electronic ballasts

## Introduction

The standard TLX5/1hr/E/T emergency controller has been re-engineered into a low profile “Slim-Line” unit. The new configuration allows the unit to be easily housed in T5 bulkheads where its predecessor could not be accommodated but still retains all the features of its predecessor. The compact size of this controller is becoming increasingly important to customers who wish to use sleeker, low profile fixtures.

Although the **TLX5/1/E/T-Slim** controller is still capable of driving all linear fluorescent lamps as well as four pin compact types from 6 to 80 Watts the “Slim” version has specifically been designed to be accommodated in T5 low profile bulkheads and is also capable of driving T5 lamps from 8 to 80W.

The emergency light output is sufficient to satisfy most escape route and anti-panic area lighting requirements.

The unit can be used with conventional switch start, electronic or dimming ballasts.

The units comply with BS EN 60598-2-22, BS EN 60924 and SABS 1464: Part 22.

Either maintained or non-maintained mode can be used. A safety start circuit is provided that prevents emergency operation until mains is connected. This enables installation without disconnecting or depleting the batteries. A battery charge indicator is incorporated.

The unit is currently housed in an alu-zinc housing.

Poke-in wire trap connectors have been added to this design which greatly simplifies connection wiring.

A splice connector version is also available where automated wiring facilities are available.

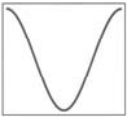

## **Specifications**

Mains voltage tolerance	230Vac +/- 10% 50 Hz
Lamp types	T5 – (8 - 80) Watt fluorescent lamps
Emergency lighting duration	1 hour
Mains power consumption	2VA
Battery discharge current	1 A
Deep discharge protection	> 0.8V/cell
Charging current	100 mA
Charging indication	provided
Quiescent current	< 1 $\mu$ A
Battery short circuit tolerance	indefinite
Weight	329g
Dimensions:-	
Controller (L x W x H):	253 x 32 x 32mm
Battery:	6v ni-cad
Maximum operating temperature	+70°C

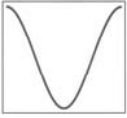

## 2.1.2 TL40/TL65 RANGE *High light output emergency control units*



### **TL40/TL65 50%** (parenthesis = TL65 50%)

The TL40 (TL65) emergency control unit provides 50% light output for one hour using either a 36 Watt or 40 Watt (58 Watt or 65 Watt) fluorescent lamp. The unit complies with SABS 1464 Part 22 and therefore provides all necessary battery charging, low voltage cut-off, protection and performance criteria. A battery pack of 5 x 4 Ahr (8 x 4 Ahr) nickel-cadmium cells is required. The unit provides an output of 20 Watts (30 Watts) and could therefore be factory set to drive other lamps. For example: 100% emergency light output could be provided using a 20 Watt (30 Watt) fluorescent lamp.

The light output may vary depending upon lamp type, ambient temperature, mains voltage and ballast, and so the light output must be measured to ensure compliance to SABS 1464 Part 22. A 10% variation must also be allowed for production spread in control units.

Either maintained or non-maintained mode can be used. A safety start circuit is provided that prevents emergency operation until mains is connected. This enables installation without disconnecting or depleting the batteries. A red pilot light indicates that the batteries are being charged. This case material has excellent high heat resistance and impact strength properties case and includes a wiring connection diagram.

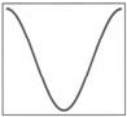

The TL40\_1/E and TL65\_1/E (above) can be used with any ballast type (switch start, electronic control gear or dimming circuits) to provide 50% light output with either a 36 Watt or 58 Watt lamp. The unit incorporates a ballast switching relay to ensure proper lamp re-ignition in instances where only the permanent mains supply is interrupted to test the emergency lighting system.

**Note 1:** Any version can be ordered with a standby switch option. This feature enables the emergency light function to be inhibited during a power failure thereby conserving battery energy. The standby switch cable must be no longer than two metres.

**SPECIFICATIONS:** (parenthesis = TL65\_50%)

Mains voltage	230 Vac +/- 10% 50 Hz
Mains consumption	< 4 VA
Lamp types	36 or 40W (58 or 65W) fluorescent lamps
Emergency lighting duration	> 1 hr
Size (L x W x H):	250 x 45 x 35mm
Battery current consumption	3 A
Deep discharge protection	4 V (7V)
Light output relative to mains	50%
Battery requirements	6V (9.6V) ni-cad cells
Charging current	190 mA
Charging indication	provided
Weight	326g
Maximum operating temperature	+70 °C
Quiescent current	< 1 µA
Battery short circuit tolerance	indefinite

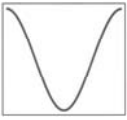

# COSINE DEVELOPMENTS

“LEADERS IN LIGHTING TECHNOLOGY”

## TL40/TL65 100%

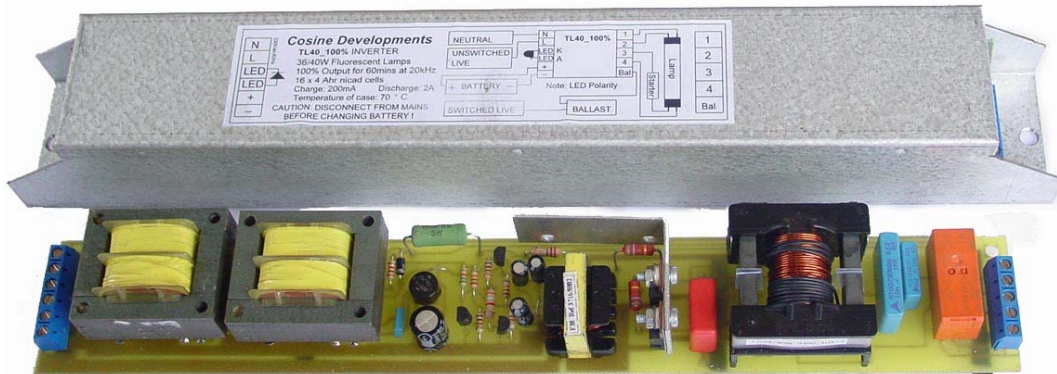

The TL40\_100% emergency control unit provides 100% light output for one hour using either a 36 Watt T8 or 40 Watt T12 fluorescent lamp. The TL65\_100% emergency control unit provides 100% light output for one hour using either a 58 Watt T8 or 65 Watt T12 fluorescent lamp. The unit complies with SABS 1464 Part 22 and therefore provides all necessary battery charging, low voltage cut-off, protection and performance criteria. A battery pack of 10 x 4 Ahr nickel-cadmium cells is required for the TL40\_100% and a battery pack of 16 x 4 Ahr nickel-cadmium cells is required for the TL65\_100% version and is available in electronic and switch start ballast.

The light output may vary depending upon lamp type, ambient temperature, mains voltage and ballast, and so the light output must be measured to ensure compliance to SABS 1464 Part 22. A 10% variation must also be allowed for production spread in control units.

Either maintained or non-maintained mode can be used. A safety start circuit is provided that prevents emergency operation until mains is connected. This enables installation without disconnecting or depleting the batteries. A red pilot light indicates that the batteries are being charged. The unit is housed in an aluzinc case which includes a wiring connection diagram.

### **SPECIFICATIONS:** (parenthesis = TL65\_100%)

Mains voltage	230 Vac +/- 10% 50 Hz
Mains consumption	< 5 VA
Lamp types	6 - 65W fluorescent lamp
Emergency lighting duration	> 1 hr
Size (l x w x h)	320 x 46 x 44 mm
Battery current consumption	3 A
Deep discharge protection	9 V (16V)
Light output relative to mains	100%
Battery requirements	12V (19.2V) nickel-cadmium cells
Charging current	190 mA
Charging indication	provided
Weight	870g
Maximum operating temperature	+70°C
Quiescent current	< 1 µA
Battery short circuit tolerance	indefinite



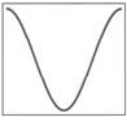

## 2.1.3 HPLD *Emergency control unit with standby feature*



The HPLD emergency control unit can be used with any ballast type and provides 50% light output in excess of three hours for fluorescent and CFL lamps.

The unit incorporates a ballast switching relay to ensure proper lamp re-ignition in instances where only permanent mains supply is interrupted to test the emergency lighting system and it is equipped with a 12V 7 Ahr maintenance free sealed lead acid battery.

The unit will operate in the case of mains or emergency and the photo electric cell will switch the HPLD on according to light levels.(on at <10 lux and off at >200 lux)

The unit complies with SABS 1464 Part 22 and therefore provides all necessary battery charging performance criteria and includes a low voltage cut-off protection circuit.

### SPECIFICATIONS

Mains voltage	230 Vac +/- 10%
Mains power consumption	<4VA
Emergency lighting duration	3 - 6 hours
Lamp type	18 - 36W T8 and 9 - 26W CFL
Changeover time (High Risk Task Area Lighting)	< 100 ms
Charging current	300mA
Battery type	12V 7Ahr sealed lead acid
Weight	870g
Dimensions (L x W x H)	247 x 41 x 36 mm
Maximum ambient temperature	+70°C

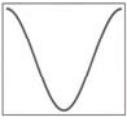

## 2.1.4 TLX\_STBY/E *Emergency control unit with standby feature*



The TLX\_STBY/E emergency control unit has a standby inhibit function to conserve battery power during a power failure. This feature is especially useful for use in sub-stations when a power failure may cause emergency lighting battery depletion before personnel arrive on site. Many emergency luminaires can be connected to the same standby switch. The maximum distance between the luminaire and the standby switch is 100 metres; more than adequate for most installations. The unit is available in both one hour and three hour duration versions. Light output and lamp types are identical to those of the standard TLX control unit (higher emergency light output versions are available upon request). Five pole relay switching ensures electronic ballast protection and safety.

The unit complies with BS EN 60598-2-22, BS EN 60924 and SABS 1464: Part 22. Either maintained or non-maintained mode can be used. A safety start circuit is provided that prevents emergency operation until mains is connected. This enables installation without disconnecting or depleting the batteries. A red light indicates that the batteries are being charged. This case material has excellent high heat resistance and impact strength properties case and includes a wiring connection diagram. The emergency light output is sufficient to satisfy most escape route and anti-panic area lighting requirements. The unit can be used with conventional switch start, electronic or dimming ballasts.

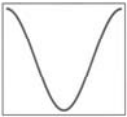

# COSINE DEVELOPMENTS

“LEADERS IN LIGHTING TECHNOLOGY”

## SPECIFICATIONS: (parenthesis = 3 hour versions)

Mains voltage tolerance	230Vac +/- 10% 50 Hz
Lamp types	6 to 80 Watt fluorescent lamps
Emergency lighting duration	(3 hours) 1 hour
Mains power consumption	2VA
Battery discharge current	1 A
Deep discharge protection	> 0.8V/cell
Charging current	(200 mA) 100 mA
Charging indication	provided
Quiescent current	< 1 µA
Weight	332g
Battery short circuit tolerance	indefinite
Dimensions:-	
Controller:	L=247 x W=45 x H=35mm
Battery:	6V ni-cad
Maximum operating temperature	+70°C

LAMP TYPE	LIGHT OUTPUT	BATTERY CURRENT	DURATION
T12: 65W	11% (9%)	1.3A (1A)	1.4 (4) hours
T8 : 58W	12% (11%)	1.3A (1A)	1.4 (4) hours
T12 : 40 W	15% (13%)	1.2A (0.8A)	1.5 (4.7) hours
T8 : 36W	18% (15%)	1.1A (0.9A)	1.6 (4.4) hours
T12 : 20 W	19% (17%)	0.6A (0.6A)	3 (6.8) hours
T8 : 18W	20% (22%)	0.7A (0.7A)	2.6 (6.1) hours
T8 : 10W	30% (32%)	0.6A (0.5A)	3 (8) hours
T5 : 8W	40% (45%)	0.7A (0.6A)	2.6 (6.8) hours
TC-DEL: 26W	32% (18%)	1.2A (0.8A)	1.5 (4.7) hours
TC-DEL: 18W	29% (26%)	1A (0.8A)	1.8 (4.7) hours
TC-DEL: 13W	36% (30%)	1A (0.6A)	1.8 (6.8) hours
TC-DD : 28W	25% (15%)	1.2A (0.7A)	1.5 (6.1) hours
TC-L : 18W	23% (19%)	0.7A (0.6A)	2.6 (6.8) hours
TC-EL : 11W	43% (42%)	0.9A (0.6A)	2 (6.8) hours
TC-EL : 9W	36% (31%)	0.6A (0.5A)	3 (8) hours
TC-EL : 7W	38% (44%)	0.7A (0.5A)	2.6 (8) hours



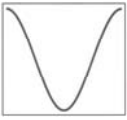

## 2.1.5 Fluorescent Lamps

## PLX Emergency control unit for 2 pin Compact



This maintained inverter can be used for two pin compact fluorescent lamps from 5 to 26 Watts. It is possible to use this unit where two 9W lamps are powered from a single ballast. One hour or three hours of emergency lighting is provided. 6V ni-cad batteries can be used with the 5, 9, 11, 13 and 2D16W lamps. Six cells must be used with both the 18 and 26W lamps. No changes to the inverter are necessary for any of the above combinations. The inverter's small external dimensions make it suitable for small luminaires. A safety start circuit is provided that prevents emergency operation until mains is connected. This enables installation without disconnecting or unnecessarily depleting the batteries. A red light is provided to indicate that the batteries are being charged and that they are in a healthy condition. Deep discharge protection is provided. The unit is available in both covered and open circuit board configurations. A remote box option is available if high temperatures or small dimensions within the proposed luminaire will result in poor reliability or an illegal installation (*i.e.*, in contravention of SABS Specifications) but wiring between inverter and lamp must be **less than three metres**.

**WIRING DIAGRAMS:** (upper diagram = single lamp, lower diagram = two lamps from one ballast)

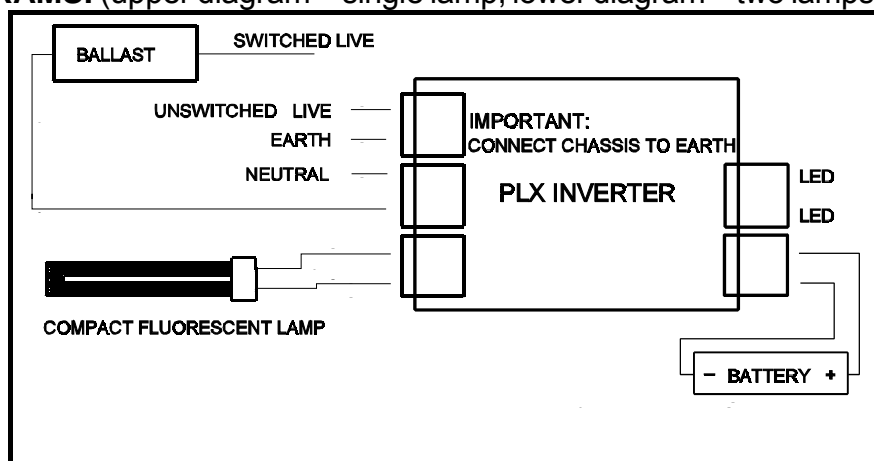

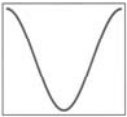

# COSINE DEVELOPMENTS

“LEADERS IN LIGHTING TECHNOLOGY”

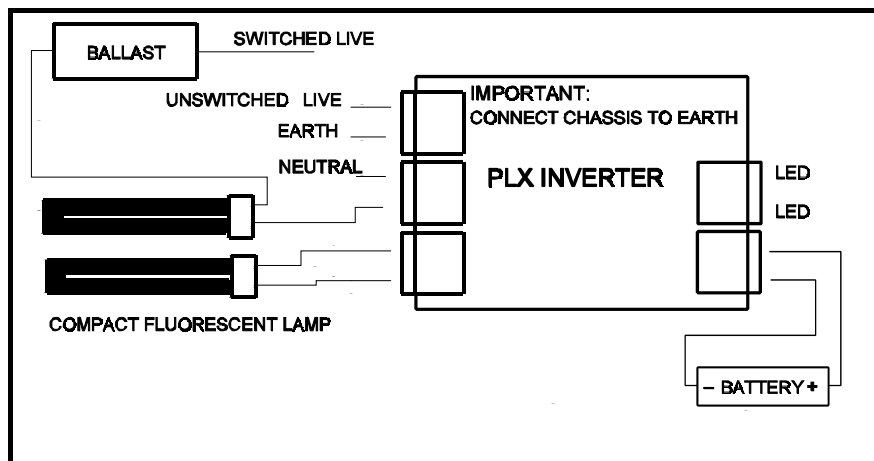

## PERFORMANCE:

LAMP TYPE	LIGHT OUTPUT Relative to mains	BATTERY CURRENT	APPROX. DURATION
26 W	40%	1.3 A	1.5 hours (6 x 2 Ahr cells)
18 W	50%	1.2 A	1.6 hours (6 x 2 Ahr cells)
	40%	1.2 A	1.6 hours (5 x 2 Ahr cells)
2D16 W	40%	1.1 A	1.8 hours (5 x 2 Ahr cells)
13 W	60%	1.1 A	1.8 hours (5 x 2 Ahr cells)
11 W	70%	1.1 A	1.8 hours (5 x 2 Ahr cells)
9 W	80%	1.0 A	2 hours (5 x 2 Ahr cells)
7 W	100%	1.0 A	2 hours (5 x 2 Ahr cells)

## ORDERING CODES:

1HR - PLX-STANDARD (Open or Closed)  
 3HR - PLX\_3hr/T

**Note 1: Luminaire/emergency gear compatibility must be ascertained before use.** Lamp starting must be tested in non-maintained mode (i.e., lamp off whilst charging) using a fresh battery pack. All metal surfaces in the luminaire must be connected to the “EARTH” terminal to assist starting. For best operation only bulkhead type fittings, where the lamp is parallel to a metal surface, should be used for both maintained and non-maintained modes. No restrictions apply to sustained operation (i.e., where the lamp is permanently on).

**Note 2:** The emergency lighting duration may vary due to cell temperature and lamp type as well as cell manufacturer.

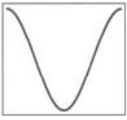

# COSINE DEVELOPMENTS

“LEADERS IN LIGHTING TECHNOLOGY”

**Note 3:** Any version can be ordered with a standby switch option. This feature enables the emergency light function to be inhibited during a power failure thereby conserving battery energy. The standby switch cable must be no longer than two metres.



Often it is not possible to cram the emergency gear into the light fitting. It is also not desirable to expose the electronics and batteries to the high temperatures inside small luminaires. In these cases the remote box (above) should be used. The remote box houses the electronics and batteries and is positioned near to the luminaire. Two 20mm cable entry holes are provided.

## **SPECIFICATIONS:** (three hour unit in parenthesis)

Lamp types:	5, 9, 11, 13, 18, 26 and 2D 16W (2 pin CFL's)
Mains voltage	230 Vac +/- 10%
Battery type	(5 or 6 x 4 Ahr cells) 5 or 6 x 2 Ahr ni-cad cells
Lighting duration	(three hours) one hour
Size	(160 x 45 x 30) 146 x 47 x 30mm
Charging current	(200 mA) 100 mA
Power conversion efficiency	>75%
Current consumption	1 - 1.4 A
Cold lamp starting (All lamps)	>5V
Weight	148g (230g)
Maximum operating temperature	+70 C
Quiescent current	< 20µA



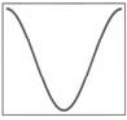

## 2.1.6 PLX-SUPERNOVA *High light output emergency control unit for 2-pin CFL's*



The PLX-SUPERNOVA emergency control unit provides 100% light output for 30 min to 1 hour using a PL-C 18W 2-pin CFL. The unit complies with SABS 1464 Part 22 and therefore provides all necessary battery charging, low voltage cut-off, protection and performance criteria. A battery pack of 5 x 4 Ahr nickel-cadmium cells is required.

The light output may vary depending upon lamp type, ambient temperature, mains voltage and ballast, and so the light output must be measured to ensure compliance to SABS 1464 Part 22. A 10% variation must also be allowed for production spread in control units.

The unit can be used as a non-maintained. A red LED indicates that the batteries are being charged. The unit is housed in an aluzinc case which includes a wiring connection diagram.

### **WIRING DIAGRAM:**

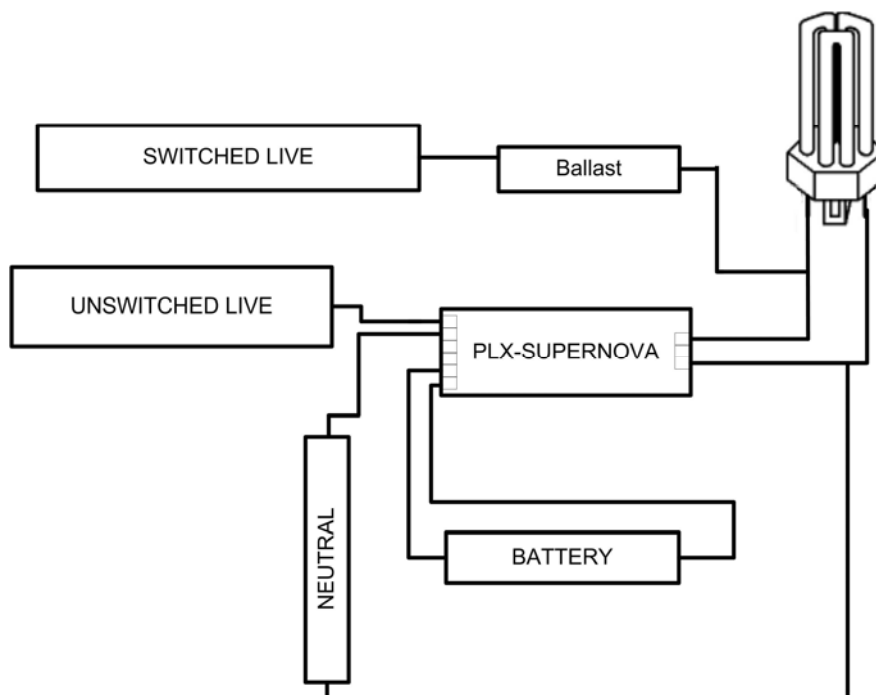

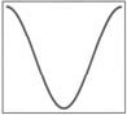

# COSINE DEVELOPMENTS

"LEADERS IN LIGHTING TECHNOLOGY"

---

## **SPECIFICATIONS:**

Mains voltage	230 Vac +/- 10% 50 Hz
Mains consumption	< 4 VA
Lamp types	PL-C 9 – 26 Compact fluorescent lamps
Emergency lighting duration	30min – 1hour
Size LxWxH	175 x 40 x 33 mm
Battery current consumption	2,5 A
Deep discharge protection	4 V (7V)
Light output relative to mains	100%
Battery requirements	6V ni-cad cells
Charging current	190 mA
Charging indication	provided
Weight	355g
Maximum operating temperature	+70°C
Quiescent current	< 1 µA
Battery short circuit tolerance	indefinite

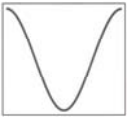

## 2.1.7 AMALGAM *Emergency control unit for triple turn PLT 4 pin lamps*



This unit is specifically designed for 18, 26, 32 and 42 Watt Master PL-T four pin type lamps (triple turn). The unit employs a unique start boost circuit to ensure proper lamp ignition thereby reducing electrode damage: a condition that results if these lamps are used with standard emergency gear. Cathode heating ensures an adequate electrode operating temperature and prevents lamp colour shift (pinking). A four pole lamp switching relay completely disconnects the lamp from the ballast during emergency operation. A ballast hold-off relay is provided to ensure reliable restarting of the ballast after emergency use. A safety start circuit is provided that prevents emergency operation until mains is connected. The unit requires a battery pack of 5 x 4Ahr ni-cad cells to provide an emergency lighting duration of 3 hours.

**SPECIFICATIONS:** (Complies with BS EN 60598-2-22 and BS EN 60924)

Mains voltage tolerance	230Vac +/- 10% 50 Hz
Lamp types	18, 26, 32and 42 Watt PL-T lamps
Emergency lighting duration	3 hours
Mains power consumption	2VA
Battery discharge current	1.03 A
Deep discharge protection	4.5V
Charging current	200 mA
Physical size (L x W x H)	230 x 46 x 37 mm
Fixing centres	215 mm
Maximum operating temperature	70°C



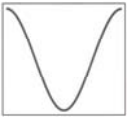

## 2.1.8 ELG-85M *Emergency lighting gear for 60 - 85W CFL's*



- **Emergency control Gear for Hi-Bay, medium & Low bay applications**
- **Maintained**
- **Drives CFL's up to 85W**
- **60 min emergency light**
- **6,000 lumens output in emergency mode**

The inability of HID lamps to re-strike after a power outage owing to the lamp having to cool off before re-striking makes non-HID lighting systems needed for emergency lighting.

A new CFL (Philips PL-H 60/85/W/840/4P) is suitable for Hi-bay, medium and Low-bay applications with a good lumen output of 6000 lumens at full power. In an emergency situation the 60/85W CFL gives sufficient light (6000 lumens) output for duration of 60minutes.

This level of light output means that the **ELG-85M** now becomes a perfect choice when high output compact fluorescent lighting is required to provide good visibility for emergency situations in an interior or exterior application when using a single 85W PL-H lamp.

### **Description**

**Control box:** The emergency control gear is a self-contained unit housed in its own housing and is mounted to a removable gear tray in the aluminium control box, which is mounted above the control gear for the lamp.

**Battery:** Two (2) 12V, 7Ahr lead acid batteries are mounted and housed next to the emergency control unit.

Only **MAINTAINED** mode can be used. A safety start circuit is provided that prevents emergency operation until mains is connected.

This enables installation without disconnecting or depleting the batteries. A red pilot light indicates that the batteries are being charged. The unit is housed in an aluzinc case, which includes a wiring connection diagram.

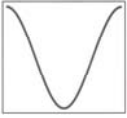

## Emergency control features

- Drives Philips PL-H 60/85W/840/4P or other fluorescent lamp types up to 85W
- Batteries: 2 x 12V 7Ahr sealed lead acid batteries.  
Duration: 60min
- Low battery discharge protection.
- Poke-in wire trap connectors greatly simplify connection wiring.

## Design Highlights

Other highlights are:-

- Measures:- L = 300mm, W = 120mm, H = 80mm

## Applications

All factories with Hi-Bay, Medium-Bay or Low-Bay fitting where emergency lighting is required.

## **SPECIFICATIONS:**

Mains voltage tolerance	230Vac +/- 10% 50 Hz
Lamp types	Fluorescent lamps up to 85W
Emergency lighting duration	1 hour
Mains power consumption	2VA
Battery discharge current	2 A
Deep discharge protection	> 0.8V/cell
Charging current	(200 mA) 100 mA
Charging indication	provided
Quiescent current	< 1 $\mu$ A
Battery short circuit tolerance	indefinite
Weight	9kg
Maximum operating temperature	+70°C
Battery specification	2 x 12V 7 Ahr sealed lead acid

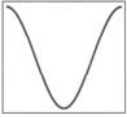

## **2.2 SELF TESTING RANGE**

### **2.2.1 THX RANGE**

- 2.2.1.1 **THX\_1hr** Self testing emergency control unit
- 2.2.1.2 **THX\_3hr** Self testing emergency control unit
- 2.2.1.3 **THX\_HP2** Self testing emergency control unit 50% for 4 ft lamp
- 2.2.1.4 **THX\_1/E** Self testing emergency control unit 20% for 4ft lamp
- 2.2.1.5 **THX\_1/E(40W)** HP for 40W 4 ft fluorescent lamp 50% for 4 ft lamp with (ECG)
- 2.2.1.6 **THX\_1/E(65W)** HP for 65W 5 ft fluorescent lamp 50% for 5ft lamp with (ECG)

2.2.2 **THX WATCH** Self testing emergency control unit with optional central display

2.2.3 **THX\_IR** Infra-red remote controlled self testing emergency control unit

2.2.4 **ELS self test** – Self testing emergency control unit

2.2.5 **THX SUPERNOVA – 2 – pin** self test emergency control unit

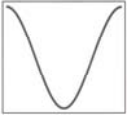

## 2.2.1 THX Range *Self testing emergency control unit*

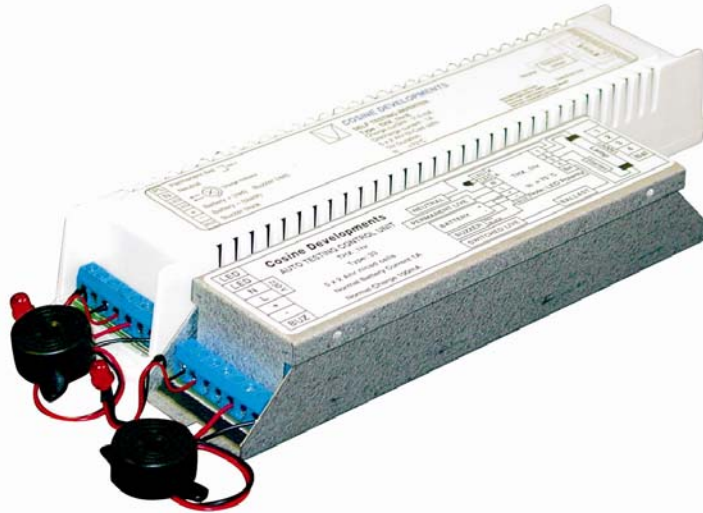

This emergency lighting control unit incorporates a self testing facility that exercises the batteries and establishes lamp condition on a regular basis. Automatic tests are conducted on a weekly basis with full functional tests every month. The weekly tests, of two minutes duration, establish battery and lamp condition whilst the monthly tests last 40 minutes in order to remove battery memory effects. System faults are reported via both audible and visual means.

### **VERSIONS:**

**THX\_1hr:** one hour emergency duration for switch start ballasts.

**THX\_3hrs:** three hours emergency duration for switch start ballasts.

**THX\_HP2:** high emergency light output (36W 50%) for switch start ballasts.

**THX\_1/E:** one hour emergency lighting duration for all ballasts (switch start, electronic control gear and dimming circuits).

**THX\_1/E HP(40W):** for 40W 4 ft fluorescent lamp 50% for 4 ft lamp for electronic control gear

**THX\_1/E HP(65W):** for 65W 5 ft fluorescent lamp 50% for 5ft lamp. Suitable for switch start and electronic control gear

### **FEATURES:**

- Automatic tests reduce maintenance requirements.
- Single unit construction for reduced wiring requirements.
- In a multi lamp fitting only one lamp is affected during tests.
- Satisfies SABS 1464 Part 22.

The indicating lamp reports the status of the batteries and the lamp by flashing at different intervals. An audible alarm emits a beep every hour of five seconds duration if a system fault is detected. The built in computer establishes whether the lamp is old, the lamp connections are sound, the battery voltage is low (shorted cell), the battery voltage is too high (old batteries) and if the batteries have lost capacity due to ageing. The user can now be aware of any problems with the emergency lighting system before power failures and not during them. The periodic use of the batteries also prolongs their life. The built in computer also prohibits deep discharging of the

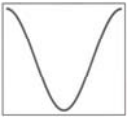

# COSINE DEVELOPMENTS

“LEADERS IN LIGHTING TECHNOLOGY”

batteries. This type of inverter is now becoming mandatory in Europe because users need some guarantee that the emergency lighting is fully functional at all times. The inverter satisfies the requirements as defined in SABS 598-1 (Luminaires: General requirements and tests) and will satisfy SABS 1464 PART 22 (Safety of luminaires: Luminaires for emergency lighting).

## LAMP INDICATION CODES:

FAULT TYPE	LED CODE		BUZZER
Mains is on and the system is OK	No flashing, LED continuously burning		Off
Battery voltage low	Continuous flashing		Beep every hour
Battery voltage too high	Three flashes followed by a pause		Beep every hour
Low capacity battery	Two flashes followed by a pause		Beep every hour
Lamp fault	One flash followed by a pause		Beep every hour
No mains	LED off		Off

## NOTES:

- The unit may be installed without the buzzer connected if necessary.
- Only connect the batteries after a permanent power supply is established *i.e.*, do not switch the unit on and off with the batteries connected during installation as this may cause damage and false error reporting.
- Faults may be cleared by switching off the permanent mains supply and temporarily disconnecting the batteries. This action will reset the internal computer chip.
- After corrective action *i.e.*, replacing faulty lamp or batteries, faults should automatically clear after the next scheduled test.
- Never attempt to replace the lamp during a self test or whilst the unit is in emergency mode. This action may cause damage and false error reporting.
- Whilst the battery is disconnected normal mains function of the emergency lamp is not possible.

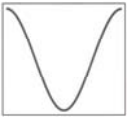

# COSINE DEVELOPMENTS

“LEADERS IN LIGHTING TECHNOLOGY”

LAMP TYPE	LIGHT OUTPUT Relative to mains	BATTERY CURRENT	APPROX. DURATION (hours) 5x2Ahr (5x4Ahr)	VERSION
T12: 65 W	13%	1.1 A	1.8 (3.6)	33
T8 : 58 W	15%	1.2 A	1.7 (3.3)	33
T12 : 40 W	17%	1 A	2 (4)	33
T8 : 36 W	20%	1.1 A	1.8 (3.6)	33
T12 : 20 W	41%	1.1 A	1.8 (3.6)	10
T8 : 18 W	44%	1.1 A	1.8 (3.6)	10
T5 : 8 W	71%	0.9 A	2.2 (4.4)	10
TC-DEL: 26W	27%	1A	2 (4)	33
TC-DEL: 18W	30%	1A	2 (4)	33
TC-DEL: 13W	38%	0.8	2.5 (5)	33
TC-DD : 16W	38%	1A	2 (4)	33
TC-DD : 26W	25%	1A	2 (4)	33
TC-L : 18W	38%	1A	2 (4)	10
TC-EL : 9W	58%	0.9	2.2 (4.4)	10

**SPECIFICATIONS:** (parenthesis = 3 hour units)

Mains voltage tolerance	230V +/- 10%
Lamp types	8 → 65W linear lamps and four pin compact lamps
Emergency lighting duration	1 hour (3 hours)
Emergency light output	see chart above
Mains power consumption	< 3VA
Battery requirements	6V ni-cad
Weight	300 – 365g
Physical size (L x W x H) HP2&1E/1hr/3hrs	247x44x36, 191x43x33 (200x46x36) mm
Maximum operating temperature	+70 °C



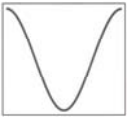

## 2.2.2 THX WATCH *Self testing emergency control unit with optional central display*



This self testing control unit requires four 4 Ahr cells to drive any lamp up to 58 W for an emergency duration of three hours. Regular tests are conducted automatically to establish the condition of the battery, charger and lamp. During these tests the unit changes over to emergency mode in order to test the lamp. If the tests reveal a fault then the indicating lamp flashes a code and an audible alarm sounds. The battery voltage is monitored on a continuous basis and if a fault occurs then the alarm sounds immediately and the code is flashed. These features ensure that the emergency lighting will function correctly when required.

### SCHEDULED TESTS:

- A monthly test (4 week intervals) of two minutes duration checks the battery, inverter and lamp.
- A six monthly test (24 weeks intervals) of one hour duration checks the battery capacity, inverter and lamp.
- An annual test (52 week intervals) of three hours duration checks the battery capacity, inverter and lamp. This test fully depletes the batteries thereby removing "memory" effects and increasing service life.

### FEATURES:

- A commissioning test is conducted exactly 48 hours after initial installation (and after a system reset). This test, of three hours duration, fully tests all emergency functions.
- Switched mains sensing ensures that self tests are not conducted during working hours *i.e.*, only after the lights have been switched off. This ensures that normal lighting levels are not affected by self tests. If the lights are on permanently then scheduled tests are delayed for 24 hours.

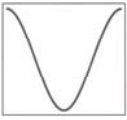

# COSINE DEVELOPMENTS

“LEADERS IN LIGHTING TECHNOLOGY”

- A test will only be conducted if the previous 24 hours was free of mains interruptions (Mains interruptions will delay a scheduled test until 24 hours of uninterrupted mains supply has been achieved).
- A system reset (to clear faults and restart test schedules) may be initiated by either momentarily disconnecting the batteries or by simply switching the light switch on and off twice within 10 seconds (On resetting, the indicator lamp will flash green once. A system reset causes the system clock to be reset and the first 3 hour test will commence 48 hours later). The ability to force a reset provides a simple method of scheduling future tests for a convenient day and time.
- A four pole relay is provided to isolate the lamp from the ballast during both self testing and emergency modes. A ballast switching relay ensures that lamp switching does not inadvertently cause ballast malfunction.
- Mains operation of emergency lamp is possible without the battery connected.
- The system complies with BS EN 60598-2-22, BS EN 60924 and Cenlec Standard CLC BTTF 62/8 (for test scheduling) as well as SABS 1464: Part 22.

## LAMP INDICATION CODES:

FAULT TYPE	LED CODE		BUZZER
Mains on - no faults	No flashing, LED continuously burning		Off
Mains on - battery fault	Red (flash once every three seconds)		Beep every hour
Mains on - lamp fault	Red (flash twice every three seconds)		Beep every hour
Mains on - battery and lamp faults	Red (flash 3 times every 3 seconds)		Beep every hour
Self test mode	Green (flash once every 14 seconds)		Off
No mains	LED off		Off

## SPECIFICATIONS

Mains voltage tolerance	230Vac +/- 10% 50 Hz
Lamp types	8 → 65 Watt fluorescent lamps
Emergency lighting duration	3 hours
Mains power consumption	2VA
Battery discharge current	1 A
Deep discharge protection	> 0.8V/cell
Charging current	200 mA
Charging indication	provided
Quiescent current	< 1 μA
Battery short circuit tolerance	indefinite
Physical size (L x W x H)	230 x 46 x 37 mm
Maximum operating temperature	+70°C



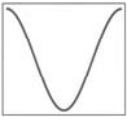

## 2.2.3

### THX\_IR *Infra-red remote controlled self testing emergency control unit*



This emergency lighting control unit incorporates a self testing facility which exercises the batteries and establishes lamp condition on a regular basis. Automatic tests are conducted on a monthly basis with full functional tests every six months. In addition the unit features an infra-red remote testing and switching control, which enables immediate testing and enables power saving when emergency operation is not required. The monthly tests, of two minutes duration, establish battery and lamp condition whilst the six-monthly tests last 30 & 60 minutes respectively in order to remove battery memory effects and test battery capacity. The indicating lamp (LED) reports the status of the batteries and the lamp by flashing at different intervals. An audible alarm emits a beep every hour of five seconds duration if a system fault is detected. The unit is available in two versions that cover all fluorescent lamp types.

#### **FEATURES:**

- Automatic tests reduce maintenance requirements.
- An initial commissioning test is conducted 48 hours after switch-on.
- Infra-red remote control.
- Remote reset allows tests to be scheduled for a convenient date and time.
- Small physical size.
- Single unit construction for reduced wiring requirements.
- In a multi lamp fitting only one lamp is affected during tests.
- Satisfies SABS 1464 Part 22.

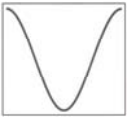

# COSINE DEVELOPMENTS

“LEADERS IN LIGHTING TECHNOLOGY”

## REMOTE CONTROL FUNCTIONS:

- **POWER SAVING:** When the Unit is in emergency mode *i.e.*, a mains failure has occurred, the lamp may be turned on or off via the handheld remote control by using the [P+] and [P-] buttons.
- **CLEARING FAULTS AND SCHEDULING TESTS:** A system reset may be forced at any time by using the [⓪] button on the remote. This function clears reported faults and resets the four week timer.
- **RANDOM TESTS ON DEMAND:** Self tests, either short or long, may be forced at any time by using the [①] , [②] or [③] buttons on the handheld remote, thus allowing more thorough inspection of the units by maintenance personnel. In addition any self-test may be shortened by the depression of the [EXIT] key on the remote to stop the test.
- **ENABLE / DISABLE ALARM:** The hourly alarm from the buzzer, when a system fault has been detected, can be disabled using the [♫] key on the handheld remote unit. The buzzer is automatically re-enabled by any self test (either automated or forced).
- **REPORT NUMBER OF AUTOMATED TESTS PERFORMED:** The unit can be interrogated to reveal the number of automated self-tests performed since the last system-reset by using the (OK) key on the handheld remote control unit. For each test performed, the unit will sound a short beep and flash the LED once, thereby allowing the user to determine the number of tests completed by counting the beeps/flashes. The test counter is automatically reset annually, so that a maximum of 12 tests will be reported in any year of operation.

**NOTE 1:** A remote reset causes the initial commissioning test (48 hours after first installation) being bypassed. The commissioning test can then be conducted manually via the remote control (force a long test) after 48 hours have elapsed since first installation.

**NOTE 2:** Although a long test can be forced at any time, it should be noted that 24-hours of uninterrupted mains supply is required to ensure that the battery has been adequately charged after a long mains failure or on first installation. In the event that a long self-test is forced before 24 hours has elapsed since the last mains failure, the unit will warn the user by sounding a five second warning beep before entering the self test mode selected. In the event of this occurring, it cannot be guaranteed that the battery has been adequately charged; hence the unit may report a faulty battery. Consequently, it is advised that the user abort any forced test proceeded by a warning beep and allow for adequate charging.

## REMOTE FUNCTIONS:

Button	Function
(P-)	Suspend Emergency operation – conserve battery
(P+)	Turn Emergency back on if suspended
⓪	Perform a system reset (Bypasses commissioning test)
①	Perform a quick test (2-minutes)
②	Perform a half hour self-test
③	Perform a one-hour self-test
(EXIT)	Stop a currently running self-test
(♫)	Disable hourly Buzzer - beep
(OK)	Report the number of automated tests performed since the last system reset

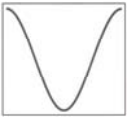

## LAMP INDICATION MODES

FAULT TYPE	LED CODE		BUZZER
Mains is on and the system is OK	No flashing, LED continuously burning	● ● ● ● ● ● ● ●	Off
Battery voltage low	Continuous flashing	● ○ ● ○ ● ○ ● ○ ◀	Beep every hour
Battery voltage too high	Three flashes followed by a pause	● ○ ● ○ ● ○ ○ ○ ◀	Beep every hour
Low capacity battery	Two flashes followed by a pause	● ○ ● ○ ○ ○ ○ ○ ◀	Beep every hour
Lamp fault	One flash followed by a pause	● ○ ○ ○ ○ ○ ○ ○ ◀	Beep every hour
No mains	LED off	○ ○ ○ ○ ○ ○ ○ ○	Off
Self Test	Flash once every 14 seconds	○ ○ ○ ○ ○ ○ ○ ●	Off

LAMP TYPE	LIGHT OUTPUT Relative to mains	BATTERY CURRENT	APPROX. DURATION (hours) 5x2Ahr	VERSION
T12: 65 W	13%	1.1 A	1.8	33
T8 : 58 W	15%	1.2 A	1.7	33
T12 : 40 W	17%	1 A	2	33
T8 : 36 W	20%	1.1 A	1.8	33
T12 : 20 W	41%	1.1 A	1.8	10
T8 : 18 W	44%	1.1 A	1.8	10
T5 : 8 W	71%	0.9 A	2.2	10
TC-DEL: 26W	27%	1A	2	33
TC-DEL: 18W	30%	1A	2	33
TC-DEL: 13W	38%	0.8	2.5	33
TC-DD : 16W	38%	1A	2	33
TC-DD : 26W	25%	1A	2	33
TC-L : 18W	38%	1A	2	10
TC-EL : 9W	58%	0.9	2.2	10

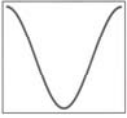

# **COSINE DEVELOPMENTS**

**"LEADERS IN LIGHTING TECHNOLOGY"**

---

## **SPECIFICATIONS**

Mains voltage tolerance	230V +/- 10%
Lamp types:	8→65W linear lamps and four pin compact lamps
Emergency lighting duration	one hour
Emergency light output	see chart
Mains power consumption	< 2W
Battery requirements	6V ni-cad
Weight	365g
Physical size (L x W x H)	191 x 43 x 34 mm
Maximum operating temperature	+70 °C

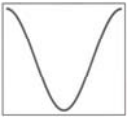

## 2.2.4 ELS Self test *Self test emergency control unit*



The **ELS self test** will provide one hour of emergency light from halogen lamps. The self testing unit will regularly conduct scheduled tests of one month and six months to check the system stability and the condition of the lamp(s) and battery. When a fault is detected the unit will flash a code and the buzzer will make an audible sound.

The unit contains a sealed lead acid battery that is charged automatically once the mains is restored. There are two indicating LED's : The green LED shows that the mains power is on and the red LED shows the battery is flat. The red LED will go off once the battery is fully charged. The unit is particularly useful for open area anti-panic emergency lighting and security lighting. If the unit is disconnected from mains for storage then the battery must be disconnected to prevent damage.

### LAMP INDICATION MODES

FAULT TYPE	LED CODE		BUZZER
Mains is on and the system is OK	No flashing, LED continuously burning	●●●●●●●●	Off
Battery voltage low	Continuous flashing	●○●○●○●○	Beep every hour
Battery voltage too high	Three flashes followed by a pause	●○●○●○●○●○	Beep every hour
Low capacity battery	Two flashes followed by a pause	●○●○●○●○●○	Beep every hour
Lamp fault	One flash followed by a pause	●○●○●○●○●○	Beep every hour
No mains	LED off	○●○●○●○●○●○	Off

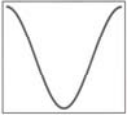

# **COSINE DEVELOPMENTS**

**"LEADERS IN LIGHTING TECHNOLOGY"**

---

## **SPECIFICATIONS**

Mains voltage	230Vac +/- 10%
Mains power consumption	9VA
Emergency lighting duration	12V dc 1 hour
Changeover time (High Risk Task Area Lighting)	<100ms
Battery protection fuse	15A
Battery type	12V 7Ahr sealed lead acid
Weight	3.911kg
Physical size (L x W x H)	280 x 80 x 112 mm
Maximum operating temperature	+70°C

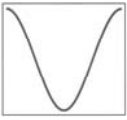

## 2.2.5 THX SUPERNOVA – 2-pin Self test emergency control unit



The **THX SUPERNOVA** will conduct a short system check every month and a deep system test every 4 months, these tests greatly improve battery life by discharging and recharging the cells on a regular basis thus preventing crystallization of the cells which causes battery life and capacity to diminish. During the tests the lamp and battery are measured and checked for faults. If a fault is detected then the unit will flash a code and the buzzer will make an audible sound.

The unit has a 30 minute switching delay for use with high pressure discharge lighting re-striking, it can still detect power failures whilst it is in warm up mode.

### LAMP INDICATION MODES

FAULT TYPE	LED CODE		BUZZER
Mains is on and the system is OK	No flashing, LED continuously burning	● ● ● ● ● ● ● ●	Off
Battery voltage low	Continuous flashing	● ○ ● ○ ● ○ ● ○ ● ○ ● ○	Beep every hour
Battery voltage too high	Three flashes followed by a pause	● ○ ● ○ ● ○ ● ○ ○ ○ ○ ○	Beep every hour
Low capacity battery	Two flashes followed by a pause	● ○ ● ○ ○ ○ ○ ○ ○ ○	Beep every hour
Lamp fault	One flash followed by a pause	● ○ ○ ○ ○ ○ ○ ○ ○ ○	Beep every hour
No mains	LED off	○ ○ ○ ○ ○ ○ ○ ○ ○ ○	Off
Self Test	Flash once every 14 seconds	○ ○ ○ ○ ○ ○ ○ ○ ●	Off

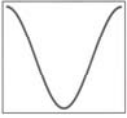

# **COSINE DEVELOPMENTS**

**"LEADERS IN LIGHTING TECHNOLOGY"**

---

## **SPECIFICATIONS**

Mains voltage	230Vac +/- 10%
Charge current	100mA
Discharge current	2.5A
Emergency lighting duration	30min – 1 hour
Battery type	6V ni-cad
Weight	418g
Physical size (L x W x H)	174 x 68 x 35 mm
Maximum operating temperature	+70 °C

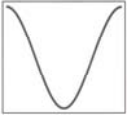

## **2.3 DOMESTIC RANGE**

- 2.3.1 **ELS\_12V** Emergency control unit for halogen lamps or luminaires
- 2.3.2 **PANTHER** Emergency Light

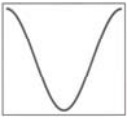

## 2.3.1 ELS 12 Volt emergency lighting system for halogen lamps or luminaires



The Emergency Lighting System (ELS) can be connected to six 8W decorative fluorescent lamps, or two 12V 20W halogen lamps or one 12V 50W lamp or a combination of different lamp types that are fitted with 12V inverters.

In the event of a power failure the unit automatically energises the lamps. Each fluorescent fitting can be switched on or off to conserve battery power during lengthy power interruptions. With one 8W luminaire the unit will provide up to eight hours of emergency light. When mains power is restored the unit automatically switches the lamps off and recharges the battery. The halogen lamps can be used in maintained mode i.e., the mains derived low voltage (fixed or dimming) supply can be used during normal conditions.

New legislation calls for emergency lighting in public areas. It is therefore illegal for casinos, pubs, shopping malls, etc. to not have emergency lighting. The unit satisfies SABS specifications and thus would satisfy mandatory requirements. An emergency lighting system would also complement a domestic alarm installation by offering additional safety for its occupants. The system is suited for D.I.Y. installation because the lamp wiring is low voltage (12 Volts) and need only be of 0.5 mm<sup>2</sup> (flex type) diameter. The central unit is directly plugged into a mains outlet and the lamp wiring can be routed through the ceiling cavity. It is also possible to use halogen spot lights for security lighting.

### **INSTALLATION:**

- Position the ELS charger near a mains outlet (It can be mounted on the wall utilising the two base slots).
- Route all lamp wires (standard 0.5 mm<sup>2</sup> flex cable) through the ceiling cavity back to the charger unit. The lamps can be secured onto the wall using double sided tape. Note: the maximum length of flex cable between the lamp and the charger unit is 20 metres.
- Connect all lamp wires to the charger (**Make sure the lamps are not connected**

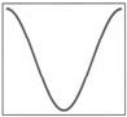

# COSINE DEVELOPMENTS

“LEADERS IN LIGHTING TECHNOLOGY”

**backwards**), i.e., the positive from the charger must be connected to the positive on the lamp). Usually the flex has identifying cotton strands with one of the bare wires to identify the positive lead.

- Open the charger lid and connect the positive battery lead and then replace the lid.
- Plug the unit into mains and switch on.

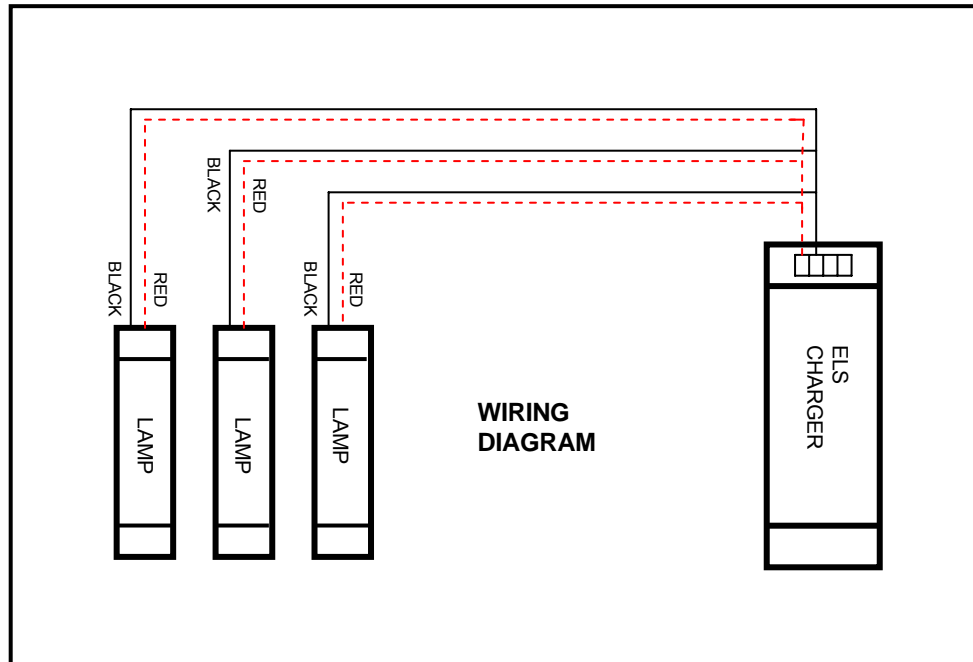

The ELS contains a battery charging circuit for its 7 Ahr lead-acid maintenance free battery. The unit has two indicating lights: the green light shows that mains power is on and the red light shows that the battery is flat. The red light will go off when the battery is fully charged. If the unit is disconnected from mains for storage then the battery must be disconnected to prevent damage.

## SPECIFICATIONS:

Mains voltage	230 Vac +/- 10%
Duration with 1 x 8 W incandescent lamp	more than 9 hours
Duration with 2 x 20 W halogen lamps	1 hour
Duration with 1 x 50 W halogen lamp	1 hour
Duration with 2 x 50 W halogen lamps	30 minutes
Duration with 1 x 8 W 12V Fluorescent lamp	8 hours
Changeover time (High Risk Task Area Lighting)	< 100 ms
Output voltage	12 V
Battery protection fuse	10 A
Battery type	12V 7Ahr sealed lead acid
Weight	3.911kg
Dimensions (L x W x H)	280 x 75 x 120mm
Maximum operating temperature	+70°C



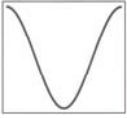

## 2.3.2 “PANTHER” “Plug-in” Portable Emergency Light

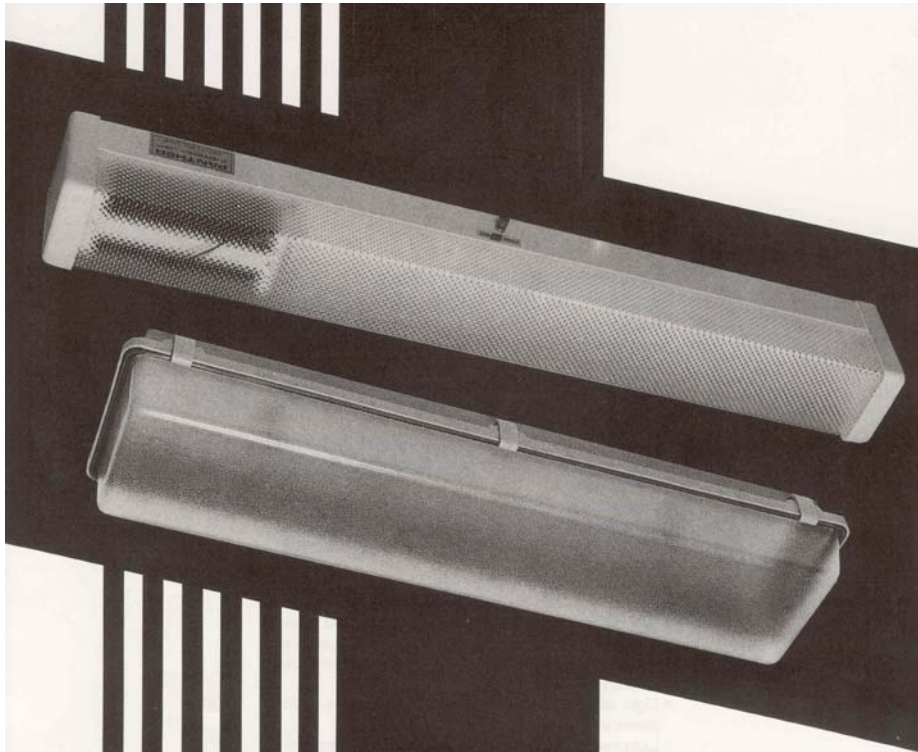

In order to be truly useful, emergency lights must be fully portable. When disaster strikes, there is no time to think about the logistics of setting up suitable lighting devices. You must be ready to act. You must have bright, reliable lighting that can go anywhere and function under any circumstances.

The PANTHER “Plug-in” portable emergency light is such a light and is suitable for domestic or industrial applications in most areas and needs no special installation. All it needs is to be connected (plug-in) to a standard 230Vac outlet. Whilst the mains is on the lamp remains off and the battery charges.

The luminaries is equipped with a 12V 7Ahr sealed lead acid battery which will operate a single a 20W fluorescent lamp at 100% illumination (1,500 lumens) for up to 4 hours.

Dual charging circuit, i.e. “boost” and “trickle” charge will ensure battery fully charged within 1½ hours.

Red LED fitted behind diffuser indicates battery being charged.

Automatic cut out when battery reaches  $\pm 10V$  in order to prevent battery from going in to “deep discharge” state.

Test button fitted to side of luminaries allows easy testing of unit.

A photo-electric cell fitted behind the diffuser will detect whether it is dark. Unit will operate in the case of mains failure and the photo-electric cell detects darkness.

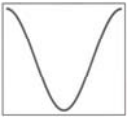

# COSINE DEVELOPMENTS

“LEADERS IN LIGHTING TECHNOLOGY”

Light will automatically illuminate when there is a mains power outage and extinguish as soon as mains power is restored.

Light level at which the unit operates is factory set.

Available in white epoxy powder coated body with prismatic acrylic wrap-around diffuser or in fibreglass dust and hose proof enclosure with high impact resistant acrylic cover.

Can be mounted to ceiling, wall or be totally portable depending on requirement.

## SPECIFICATIONS:

Mains voltage	230 Vac +/- 10%
Duration with 1 x 20W Fluorescent lamp	4 hours
Changeover time (High Risk Task Area Lighting)	< 100 ms
Battery protection fuse	2 A
Battery type	12V 7Ahr sealed lead acid
Maximum ambient temperature	=40°C

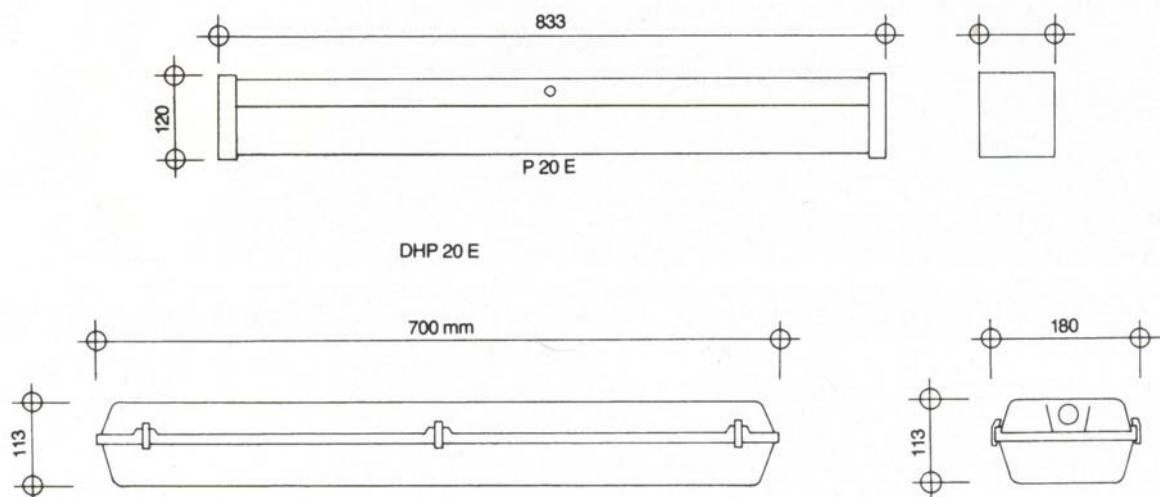

Dimensions in mm



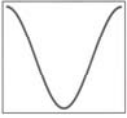

## **2.4 HIGH RISK TASK AREAS RANGE**

- 2.4.1 **ELS\_SPOT** Emergency control gear with two 20W halogen spot lamps
- 2.4.2 **ELS\_BIG BEAM** Emergency control gear with two 50W halogen lamps
- 2.4.3 **ELS\_MINI WEDGE** Emergency control gear with a fluorescent flood light
- 2.4.4 **ELS\_NICAD** Emergency control gear for low voltage down-lights
- 2.4.5 **ELS\_HP** Three hour emergency spot-light unit

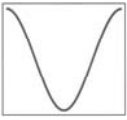

## 2.4.1 ELS\_SPOT *Emergency control unit with two 20W halogen spot lamps*



The ELS\_SPOT will provide one hour of emergency lighting with two 20 Watt halogen lamps. The lamps are swivel mounted so that emergency light may be directed where necessary. This unit is particularly useful for high risk task area lighting where instant bright emergency light is required. Typical examples are security lighting, cashiers, casino tables and for moving machinery. The unit contains a sealed lead-acid maintenance free battery that is charged automatically once the mains power is restored. There are two indicating lights: the green light shows that mains power is on and the red light shows that the battery is flat. The red light will go off when the battery is fully charged. If the unit is disconnected from mains for storage then the battery must be disconnected to prevent damage.

### **SPECIFICATIONS:**

Mains voltage	230 Vac +/- 10%
Mains power consumption	9VA
Emergency lighting duration	one hour
Changeover time (High Risk Task Area Lighting)	< 100 ms
Battery protection fuse	10 A
Battery type	12V 7Ahr sealed lead acid
Weight	3.911kg
Dimensions (L x W x H)	280 x 75 x 120mm
Maximum ambient temperature	+70°C



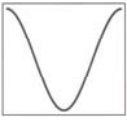

## 2.4.2 ELS\_BIG BEAM Emergency control unit with two 50W halogen lamps



The ELS\_BIG BEAM will provide twenty minutes of emergency lighting with two 50 Watt halogen lamps. The lamps are swivel mounted so that emergency light may be directed where necessary. This unit is particularly useful for high risk task area lighting where instant bright emergency light is required. Typical examples are security lighting, cashiers, casino tables and for moving machinery. The unit contains a sealed lead-acid maintenance free battery that is charged automatically once the mains power is restored. There are two indicating lights: the green light shows that mains power is on and the red light shows that the battery is flat. The red light will go off when the battery is fully charged. If the unit is disconnected from mains for storage then the battery must be disconnected to prevent damage.

### **SPECIFICATIONS:**

Mains voltage	230 Vac +/- 10%
Mains power consumption	9VA
Emergency lighting duration	20 minutes
Changeover time (High Risk Task Area Lighting)	< 100 ms
Battery protection fuse	10 A
Battery type	12V 7Ahr sealed lead acid
Weight	3.911kg
Dimensions (L x W x H)	280 x 75 x 120mm
Maximum ambient temperature	+70°C



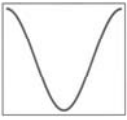

## 2.4.3 ELS\_MINI WEDGE *Emergency control unit with a fluorescent floodlight*



The ELS\_MINI WEDGE will provide seven hours of emergency lighting from a 9Watt fluorescent lamp housed within a flood type luminaire. This unit is particularly useful for open area anti-panic emergency lighting and security lighting. The unit contains a sealed lead-acid maintenance free battery that is charged automatically once the mains power is restored. There are two indicating lights: the green light shows that mains power is on and the red light shows that the battery is flat. The red light will go off when the battery is fully charged. If the unit is disconnected from mains for storage then the battery must be disconnected to prevent damage.

### **SPECIFICATIONS:**

Mains voltage	230 Vac +/- 10%
Mains power consumption	9VA
Emergency lighting duration	7 hours
Changeover time (High Risk Task Area Lighting)	< 100 ms
Battery protection fuse	10 A
Battery type	12V 7Ahr sealed lead acid
Weight	3.911kg
Dimensions (L x W x H)	280 x 100 x 360mm
Maximum ambient temperature	+70°C



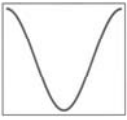

## 2.4.4 ELS\_NICAD *Emergency control gear for low voltage down-lights*

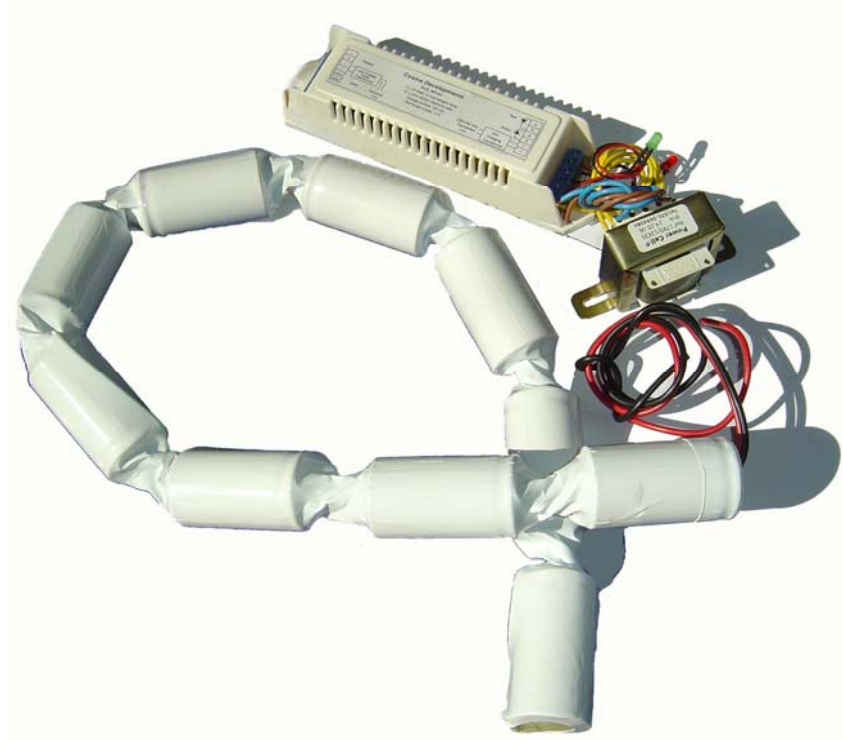

This system has been designed to fit through the down-light hole into the ceiling cavity. It can drive one 20 or 50 Watt halogen lamp for an emergency lighting duration of one hour. The unit can be used in maintained mode (where the normal low voltage supply, fixed or dimming, is routed through the unit). A battery pack of 10 x 2Ahr is required for a 20 W lamp. A battery pack of 10 x 4Ahr is required for a 50 W lamp.

### **SPECIFICATIONS:** (parenthesis = 50W)

Mains voltage tolerance	230Vac +/- 10% 50 Hz
Lamp types	20W (50W) 12 V Halogen lamps
Emergency lighting duration	1 hour
Mains power consumption	9VA
Battery discharge current	1.7A – 20W (4.3A – 50W)
Deep discharge protection	> 0.8V/cell
Charging current	200mA
Charging indication	provided
Quiescent current	< 1 $\mu$ A
Changeover time (High Risk Task Area Lighting)	< 100 ms
Output voltage	12 V
Battery protection fuse	10 A
Weight	123g
Dimensions	170 x 44 x 34mm
Maximum operating temperature	+70°C



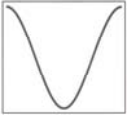

## 2.4.5 ELS HP *Three hour emergency spot-light unit*



The ELS\_HP will provide three hours of emergency lighting with two 20 Watt halogen lamps. The lamps are swivel mounted so that emergency light may be directed where necessary. This unit is particularly useful for high risk task area lighting where instant bright emergency light is required, and for open area anti-panic lighting. Typical examples are security lighting, cashiers, casino tables and for moving machinery. The unit contains a sealed lead-acid maintenance free battery that is charged automatically once the mains power is restored. There are two indicating lights: the green light shows that mains power is on and the red light shows that the battery is flat. The red light will go off when the battery is fully charged. If the unit is disconnected from mains for storage then the battery must be disconnected to prevent damage.

### **SPECIFICATIONS:**

Mains voltage	230 Vac +/- 10%
Mains power consumption	9VA
Duration	3 hours
Lamp type	2 x 20W halogen
Changeover time (High Risk Task Area Lighting)	< 100 ms
Battery type	12V 17Ahr sealed lead acid
Weight	9,5kg
Dimensions (L x W x H)	300 x 140 x 330mm
Maximum ambient temperature	+70°C



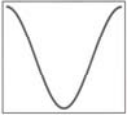

## **2.5 INTELLIGENT RANGE**

2.5.1 **INTELLITE** Self testing emergency spot light with remote control

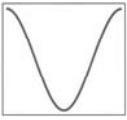

## 2.5.1 INTELLITE *Self testing emergency spot light with remote control*



The INTELLITE Emergency Luminaire provides one hour of emergency lighting using a 50 Watt halogen lamp. The unit is particularly suitable where instantaneous, bright light is required during power failures for hi-bay lighting, security lighting, high-risk task areas and moving machinery. The unit also has an eight minute switch-on delay to allow for the re-striking of high pressure fluorescent lighting. A built-in self testing function automatically conducts regular tests to ensure that the unit is fully functional. A monthly test of two minutes duration verifies the functionality of the lamp, battery and emergency circuitry. A six monthly test of 30 minutes duration confirms the battery capacity. Faults are reported via both audible and visual means: An indicator lamp will flash a code identifying either a battery or lamp failure and the buzzer will sound every hour.

### **FEATURES:**

- Infra-red remote control enables the user to initiate self tests and switch the emergency light on and off thus preserving the battery during power failures. The user can also reset faults, disable the buzzer and interrupt self tests.
- The infra-red range is in excess of 13 metres, useful in high ceiling installations.
- Eight minute switch-on delay for high pressure discharge lighting re-striking.
- Tests are conducted automatically to determine the condition of the battery, charger and lamp. If the test reveals a fault, then the indicating LED's flashes a distinct code and an audible alarm sounds.
- The system complies with BS EN 60598-2-22, BS EN 60924 and Cenlec Standard CLC BTTF 62/8 (for test scheduling) as well as SABS 1464: Part 22.

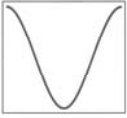

# COSINE DEVELOPMENTS

“LEADERS IN LIGHTING TECHNOLOGY”

## SCHEDULED TESTS:

- A monthly test of two minutes duration tests the battery and lamp.
- A six monthly test of 30 minutes duration checks battery capacity and the lamp.

The first automated test will occur one month (30 days) after first initialisation. Monthly tests occur at four week intervals. If a mains failure occurs during a test, the test will continue uninterrupted. If mains restoration has not occurred by the end of the test, then the unit will remain in emergency mode until mains is restored. No six-monthly test will occur until the previous 24-hours has been free of mains interruptions, however, a six-monthly test (half-hour) may be forced at any time via the remote control.

The reported faults and scheduled tests may be cleared by either:

- Connecting battery before mains.
- Connecting mains before battery.
- Selecting the reset command on the remote control.

On resetting, the indicator lamps will flash once and the buzzer will sound for half a second.

Two indicating lamps, red and green, are used to identify system status. If a fault is detected, the buzzer will sound immediately after the test, and then at hourly intervals until the fault is rectified. The type of fault is indicated by the following table: -

MODE	INDICATOR	BUZZER
Mains on – No faults	Green steady	Off
Mains on – Batt. disconnected	Green Steady	Off
Mains on – Batt. fault	Red flash once every 3sec	Beep every hour
Mains on – Lamp fault	Red flash twice every 3sec	Beep every hour
Mains on – Batt. +Lamp fault	Red flash thrice every 3 sec	Beep every hour
Mains off – Emergency mode	Off	Off
Batt. below threshold or Batt. Connected before mains	Off	Off
Self Test Mode	Red + Green flash every 5sec	Off
Battery connected and charging	Yellow Led on	N/A
Battery connected and charged	Yellow Led off	N/A

NB. Once activated, the buzzer may be disabled via the remote control unit. The buzzer is automatically enabled via a self-test.

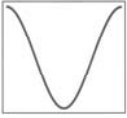

# COSINE DEVELOPMENTS

“LEADERS IN LIGHTING TECHNOLOGY”

## Remote Functions:

Button	Function
P-	Suspend Emergency operation – conserve battery
P+	Turn Emergency back on if suspended
0	Perform a system reset
1	Perform short self-test (2-minutes)
2	Perform long self-test (half-hour)
♪	Disable hourly buzzer (beep)
EXIT	Stop a currently running self-test

**NOTE:** Although a long test can be forced at any time, it should be noted that a minimum of 24-hours of uninterrupted mains supply is required to ensure that the battery has been adequately charged after a long mains failure.

## SPECIFICATIONS:

Mains voltage	230 Vac +/- 10%
Mains power consumption	9VA
Duration	1 hour
Lamp type	12V 50W halogen
Changeover time (High Risk Task Area Lighting)	< 100 ms
Battery protection fuse	10 A
Battery type	12V 7Ahr sealed lead acid
Dimensions (L x W x H)	290 x 140 x 175mm
Remote range	13m
Weight	4kg
Floor illumination level at 6m mounting height	40 lux
Maximum operating temperature	+70 °C



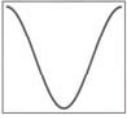

## **2.6 CENTRAL BATTERY SYSTEM RANGE**

### **2.6.1 CENTRAL BATTERY SYSTEM** Centralised emergency lighting

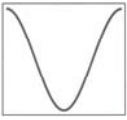

## 2.6.1 CENTRAL BATTERY SYSTEM *Centralised emergency lighting System*



### OVERVIEW

Our Central Battery Systems are installed where the benefits of central control and maintenance are desired in small premises and provides a competitive solution. The System features a centralised battery pack (48V) connected to satellite emergency luminaires. A maximum of thirty emergency luminaires may be connected to the central battery pack thereby reducing installation cost. Maintenance costs are dramatically reduced as battery replacement does not require individual luminaire access, traditionally a problem, as batteries usually require replacement every three years. Each emergency luminaire contains an emergency module (TL48\_EM) to enable maintained operation. The modules are specifically designed to protect associated electronic ballasts from open circuit (no lamp) conditions. Also, the emergency modules are polarity insensitive thereby simplifying wiring. A typical installation will be a dedicated central battery supply for each floor (storey) supplying all emergency lighting for that floor (exit, anti-panic and stair-well lighting). A standby facility is included to preserve battery power in the event of extended mains failures.

The industry standard emergency lighting system consists of a battery pack and an emergency control unit built into the luminaire. The luminaire is then fed by an extra permanent live connection to charge the batteries and detect power failures.

The extra connection enables the luminaire to be used for both normal and emergency lighting (so called *maintained* operation). This option is preferred to motor generator sets because they will be activated when the power supply failure is restricted to a particular circuit or floor (SABS 0114-2).

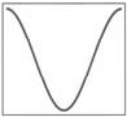

# COSINE DEVELOPMENTS

“LEADERS IN LIGHTING TECHNOLOGY”

The emergency luminaires may be installed in shopping malls, airport departure halls, banking halls, restaurants, sports stadiums, warehouses, *etc.*

Periodic luminaire maintenance requires re-lamping and, if necessary, reflector cleaning. It is generally accepted that emergency luminaire batteries be replaced every three years assuming that the batteries were mounted in the coolest part of the luminaire. The battery replacement could coincide with the re-lamping exercise thereby defraying costs but replacing batteries is usually considerably more time consuming than replacing lamps often because no consideration was given before mounting the batteries initially.

A strong case is therefore made for centrally supplied emergency luminaires where a central battery is connected to satellite emergency luminaires via a low voltage cable feed as shown in the figure below.

## GENERAL DESCRIPTION

### General

The Central Battery System (CBS) consists of a base station and inverter modules. The base station houses the batteries, battery charger and supervisory circuitry. It is housed in an attractive enclosure that is ideally positioned for easy access, usually on every floor of multi storey buildings. The base station provides 48V dc during a power failure to the emergency lighting luminaires via 2mm dia. *Surfix* cable. The inverter modules are fitted into each emergency luminaire and can be configured to provide maintained or non-maintained emergency lighting.

### Base station

The base station requires a permanent 230V ac mains connection in order to charge the batteries and to detect power failures. Four 12V 7Ahr sealed lead-acid batteries are housed within the base station. The battery charger is capable of charging the batteries within 24 hours, in accordance with SABS/IEC 1464 part 22, provide over-voltage and low-voltage protection as well as other necessary requirements. In the event of a power failure the output voltage (48V dc) is supplied to the emergency light fittings.

### Inverter Modules

The inverter modules are fitted within the emergency luminaires. They connect the lamp to the ballast under normal conditions so that the luminaire can be used for normal lighting (maintained operation). In the event of a power failure the lamp is energised by the inverter. A special sense circuit is included to prevent emergency operation during normal lighting thereby protection the electronic ballast (if used) from open circuit (no lamp) conditions. Each inverter module draws less than 150 mA so that a maximum of 24 emergency luminaires can be connected to each base station ( $24 \times 150 \text{ mA} = 4.5 \text{ A}$ ) thereby ensuring a minimum emergency lighting duration of one hour. The low current draw and volt drop tolerance of the inverter modules permits cable runs of 100 m using 2 mm dia. *Surfix*.

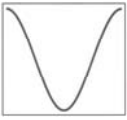

## Luminaire Requirements

Any four pin fluorescent lamp from 7 to 65 Watts can be used. This includes linear T12, T8, T5 and compact fluorescent types.

## Maintained Mode

For maintained mode (where the luminaire is also used for both normal and emergency lighting) the luminaire must house both the electronic ballast and the inverter module. The electronic ballast must be provided with a switched live feed (230Vac) to provide normal lighting. The inverter module must be supplied by the 48V dc feed from the base station. The emergency lamp will be connected to the electronic ballast via the inverter module. In the event of a power failure the 48Vdc feed from the base station will be energised and the emergency lamp will be powered from the inverter module.

## Non-Maintained Mode

For non-maintained mode (where the luminaire is only used for emergency lighting) the luminaire need only house the inverter module, i.e., no electronic ballast and switched live feeds are required. The only feed to the luminaire will be the 48Vdc feed from the base station.

## CENTRAL BATTERY SYSTEM

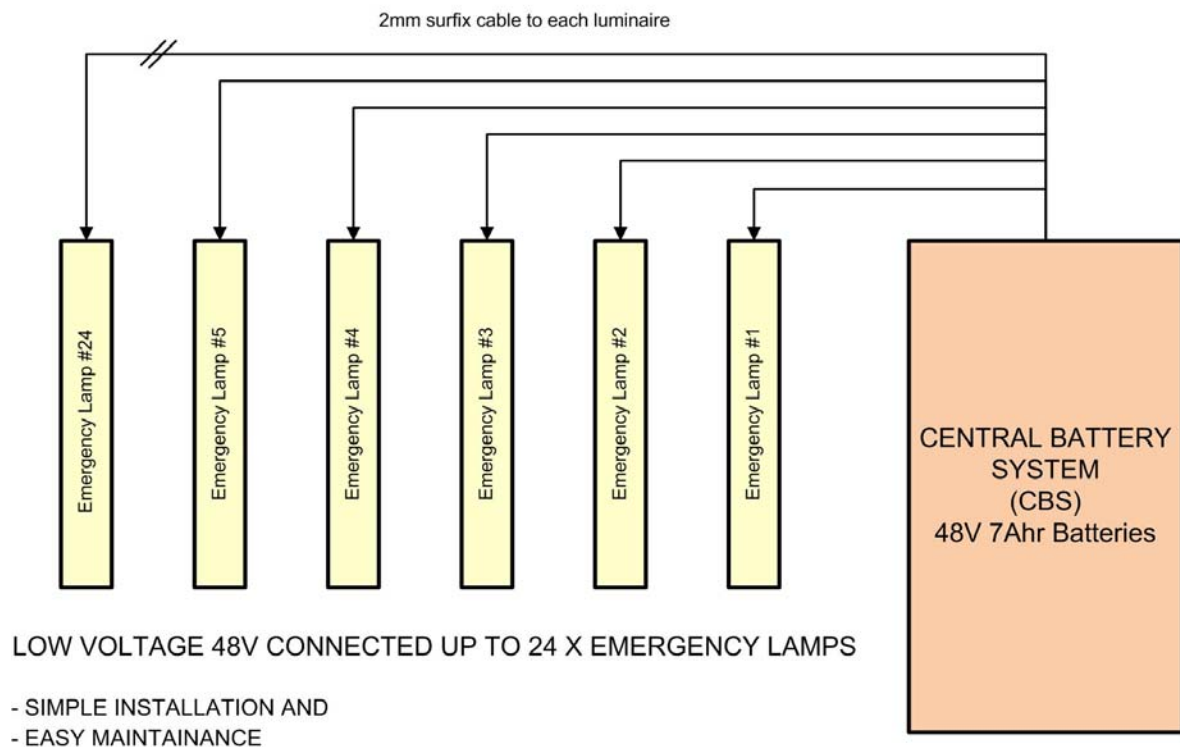

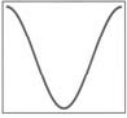

# **COSINE DEVELOPMENTS**

**“LEADERS IN LIGHTING TECHNOLOGY”**

---

## **FEATURES:**

- Initial costs are comparable to self contained luminaires.
- Battery costs are considerably lower.
- Maintenance costs are reduced.
- Reliability is improved due to a dramatic reduction in battery ambient heat.
- The current practice of shoe horning emergency gear into luminaires, is avoided, prolonging battery life, as batteries are not stored near a heat-source.
- Downtime due to period maintenance requirements is reduced.

## **SUGGESTED INSTALLATIONS:**

While the CBS can be installed where ever there is a need for emergency lighting, some of the following locations are ideally suited to it's installation.

Factories, Warehouses, Office-buildings, Airports, Schools and Educational institutions, Hospitals Auditoriums, Banking Halls, Restaurants, Shopping Malls, Parking Lots, Sports stadiums etc.

## **SPECIFICATIONS:**

Mains voltage	230 Vac +/- 10%
Output voltage	48 V dc
Duration	1 or 3 hours
Lamp types	all fluorescent lamp types
Emergency light output (BLF)	20%
Maximum cable length (2.0mm $\Phi$ )	100m
Maximum number of luminaires	24
Weight	15kg
Battery type	4 x 12V 7Ahr sealed lead acid
Dimensions (D x W x H)	170 x 400 x 300mm
Maximum operating temperature	+70°C



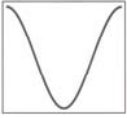

## **3. BATTERIES**

### 3.1 **BATTERIES** *Battery packs for emergency lighting*

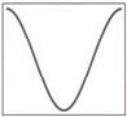

## 3.1 BATTERIES *Battery packs for emergency lighting*



A wide variety of battery packs specifically selected for emergency lighting operation is available:

BATTERY	TYPE	VOLTAGE	DIMENSIONS	WEIGHT
10 x 4 Ahr	nickel cadmium	12Volts	320 x 62 x 36mm	1.268g
8 x 4 Ahr	nickel cadmium	9.6Volts	260 x 62 x 36mm	1.041g
6 x 4 Ahr	nickel cadmium	7.2Volts	195 x 62 x 36mm	825g
5 x 4 Ahr	nickel cadmium	6Volts	160 x 62 x 36mm	634g
3 x 4 Ahr	nickel cadmium	3.6Volts	95 x 62 x 36mm	360g
10 x 2 Ahr	nickel cadmium	12Volts	220 x 46 x 26mm	586g
8 x 2 Ahr	nickel cadmium	9.6Volts	179 x 46 x 26mm	413g
6 x 2 Ahr	nickel cadmium	7.2Volts	134 x 46 x 26mm	332g
5 x 2 Ahr	nickel cadmium	6Volts	110 x 46 x 26mm	278g
3 x 2 Ahr	nickel cadmium	3.6Volts	67 x 46 x 26mm	158g
12V 7 Ahr	sealed lead-acid	12Volts	151 x 65 x 95mm	2.472g
6 x 4 Ahr	Sausage ni-cad	7.2Volts	33 x 375 mm	742g
10 x 4 Ahr	Sausage ni-cad	12Volts	33 x 925mm	1.169g

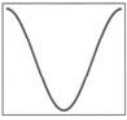

## **4. INVERTERS**

- 4.1 **TL12/24/48Vdc** Fluorescent lamp inverters for dc supplies
- 4.2 **TL12dc/2 & TL24dc/2** Dual fluorescent lamp inverter for 12V dc supplies
- 4.3 **TL24/40Vdc** Range
  - 4.3.1 **TL20/\_24Vdc** Fluorescent lamp inverters for railway coach lighting  
and  
**TL20/\_110Vdc** Fluorescent lamp inverters for railway coach lighting
  - 4.3.2 **TL40\_24Vdc** Fluorescent lamp inverters for railway coach lighting  
and  
**TL40\_110Vdc** Fluorescent lamp inverters for railway coach lighting
- 4.4 **TL20** Range
  - 4.4.1 **TL20\_75Vdc** Fluorescent lamp inverters for high dc voltages
  - 4.4.2 **TL20\_110Vdc** Fluorescent lamp inverters for high dc voltages
- 4.5 **TL24Vac or TL32Vac** Fluorescent lamp inverter for 24Vac and 32Vac supply voltage
- 4.6 **TL32Vac\_SUPREME** – 42W Fluorescent lamp inverter for 32Vac supply voltage

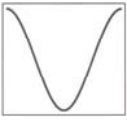

## 4.1 TL12/24/48Vdc Fluorescent lamp inverters for dc supplies



These inverters can drive any four pin fluorescent lamp from dc supplies (TL12V = 12V, TL24V = 24V, TL48V = 48V). Bi-axial fluorescent lamps from 7 to 40 Watts and four pin compact fluorescent lamps can be used. It can be used for emergency lighting, standby lighting, automotive and industrial applications. Optimal design ensures long lamp life and reliable lamp ignition. Design features include high power conversion efficiency, high lumen efficacy, high supply immunity (for automotive applications) and input fuse protection. No damage will result if the lamp is removed whilst the power is on or if the lamp fails.

### **SPECIFICATIONS:**

Nominal Input voltage	TL12V = 12Vdc, TL24V = 24Vdc, TL48V = 48Vdc
Input current (depends upon the lamp)	maximum 3 A
Lamp types:	7→40W four pin fluorescent lamps
Size	171 x 45 x 35 mm
Input fuse protection	5 A
Power conversion efficiency	80%
Weight	161g
Operating frequency	30 kHz
Maximum operating temperature	+70°C



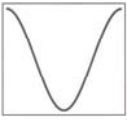

## 4.2 TL12Vdc/2 & TL24Vdc/2 Dual fluorescent lamp inverter for 12V & 24V dc supplies



This inverter can drive **twin** four (4) pin fluorescent lamps from a 12V or 24V dc supply. Bi-axial fluorescent lamps from up to 36 Watts and four pin compact fluorescent lamps up to 26W can be used. The TL12/2 or TL24/2 inverter can be used for emergency lighting, standby lighting, automotive and industrial applications. Optimal design ensures long lamp life and reliable lamp ignition. Design features include high power conversion efficiency, high lumen efficacy, high supply immunity (for automotive applications) and input fuse protection. No damage will result if the lamp is removed whilst the power is on or if the lamp fails.

### **SPECIFICATIONS:** (TL24Vdc/2 unit in parenthesis)

Nominal Input voltage	12 - 14Vdc (24 -26Vdc)
Input current (depends upon the lamp)	maximum 4 A
Lamp types:	2 x 18→36W four pin Bi-axial fluorescent lamps 2 x 9→26W four pin Compact fluorescent lamps
Size (l x w x h)	250 x 45 x 35 mm
Fixing centres	230 mm
Input fuse protection	5 A
Power conversion efficiency	80%
Operating frequency	30 kHz
Weight	272g
Maximum operating temperature	+70°C



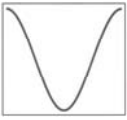

## 4.3 TL20/40\_24Vdc Fluorescent lamp inverters for railway coach lighting



These fluorescent lamp inverters are specifically designed for transport lighting. They feature both transient and sustained over-voltage protection, reverse polarity connection, fusing and lamp failure tolerance. Automatic cut-off protects both the lamp and inverter during both over and under-voltage conditions. The unit is also tolerant to interchanging of lamp and supply connections. Both 24V dc and 110V dc versions are available to power a single 20 W fluorescent lamps (TL20\_24V, TL20\_110V)

The (TL40\_24V, TL40\_110V) may also be used to power double 20W fluorescent lamps. It is housed in an aluminium enclosure with Phoenix plug-in connectors for power and lamp terminations. It is designed to cope with harsh temperature extremes, vibration and “dirty” voltage supplies commonly experienced in transport environments. Lamp ignition is guaranteed through cathode heating and long lamp life is ensured by a near ideal discharge current. The unit satisfies IEC 924, IEC 925 and IEC 60081. Versions are available to drive any fluorescent lamp from 6 to 20 Watts.

### **SPECIFICATIONS** (parenthesis = 110V units)

Nominal Input voltage	24V dc (110V dc)
Over voltage cut-off	38V (140V)
Under voltage cut-off	18V (90V)
Operating Frequency	24 kHz
Maximum operating temperature	70°C
Weight	238g
Lamp types	6 → 40W
Size (L x W x H)	150mm x 65mm x 42mm



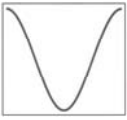

## 4.4 TL20\_75/110Vdc Fluorescent lamp inverters for high dc voltages



These inverters drive a single fluorescent lamp (15, 18 or 20 Watts) from either 75V dc (TL20\_75Vdc) or 110V dc (TL20\_110Vdc). It can be used for emergency lighting, standby lighting, automotive and industrial applications. Optimal design ensures long lamp life and reliable lamp ignition. Design features include high power conversion efficiency, high lumen efficacy, high supply immunity (for automotive applications) and input fuse protection. No damage will result if the lamp is removed whilst the power is on or if the lamp fails.

**SPECIFICATIONS:** (parenthesis = TL20\_75Vdc)

Input voltage range (lamp ignition range)	(50...90V) 80...130 V
Input current	180 mA
Operating Frequency	25 kHz
Maximum operating temperature	70°C
Weight	288g
Box size (L, H, W)	215 x 32 x 42 mm



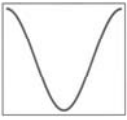

## 4.5 TL24Vac/STD & 32Vac/STD Fluorescent lamp inverter for 24Vac & 32Vac supply voltage



The TL24Vac & TL32Vac can drive any four pin compact fluorescent lamps PL18 and PL26W from a 24Vac or 32Vac supply. It can be used for emergency lighting, standby lighting, and industrial applications. Optimal design ensures long lamp life and reliable lamp ignition. Design features include high power conversion efficiency, high lumen efficacy, high supply immunity (for automotive applications) and input fuse protection. No damage will result if the lamp is removed whilst the power is on or if the lamp fails.

### **SPECIFICATIONS:**

Nominal Input voltage	24Vac or 32V ac
Input current (depends upon the lamp)	maximum 2 A
Lamp types:	18→26W four pin CFL
Size	171 x 45 x 35 mm
Input fuse protection	2 A
Power conversion efficiency	80%
Weight	169g
Operating frequency	30 kHz
Maximum operating temperature	+70°C



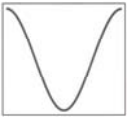

# COSINE DEVELOPMENTS

“LEADERS IN LIGHTING TECHNOLOGY”

## 4.6 32Vac\_SUPREME 42W Fluorescent lamp inverter for 32Vac supply voltage



The TL32Vac\_SUPREME can drive any four pin PL42W compact fluorescent lamp from a 32Vac supply. It can be used for emergency lighting, standby lighting, and industrial applications. Optimal design ensures long lamp life and reliable lamp ignition. Design features include high power conversion efficiency, high lumen efficacy, high supply immunity (for automotive applications) and input fuse protection. No damage will result if the lamp is removed whilst the power is on or if the lamp fails.

### **SPECIFICATIONS:**

Nominal Input voltage	32Vac
Input current (depends upon the lamp)	maximum 2 A
Lamp types:	PL42W four pin CFL
Size	171 x 45 x 35 mm
Input fuse protection	2 A
Power conversion efficiency	80%
Weight	169g
Operating frequency	30 kHz
Maximum operating temperature	+70°C



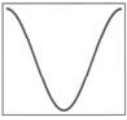

## 6.5 Electronic Ballasts



The **COSINE DEVELOPMENTS** electronic ballasts for compact fluorescent lamps are housed in a plastic casing and they are designed to operate double compact fluorescent lamps. The applications vary from Restaurant's, Hotel's, to Showroom's, Meeting room's etc.

The ballasts pre-heat the lamps so the electrodes don't get damaged during lamp striking thus increasing lamp life and it is also suitable for use with occupancy sensors.

Due to above 20KHz operating frequency, the lighting efficiency of **COSINE DEVELOPMENTS** brand ballast will be raised by 10% if compared with Electromagnetic ballasts. No flicker, no noise and good for health. The ballasts have a built in power factor corrector.

The ballasts have automatic protection from damage under abnormal conditions, such as lamp is disconnected and lamp fails to start, the ballasts auto-reset after lamp replacement.

Satisfies SABS requirements.

### **SPECIFICATIONS:**

Nominal Input voltage	220Vac
Input current (depends upon the lamp)	120mA
Lamp types:	PL9,13,18,26W
Size (L x W x H)	123.2 x 79 x 33.2 mm
Power conversion efficiency	80%
Operating frequency	20 kHz
Weight 9,13,18,26	60 - 220g
Maximum case temperature (tc)	+65°C

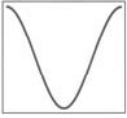

## **6.5 LIGHT CONTROL GEAR**

### **PHOTOCELLS**

**DN1** Day/Night switch – heavy duty

**DN2..DN2-L** Day/Night switch – CFL loading

**DN3** Day/Night switch – HID loading

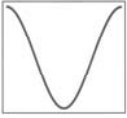

## 6.1 **DN1** *Day/Night switch – heavy duty*



The **DN1** is a rugged and reliable photocell designed specifically for the harsh conditions of streetlight switching. Years of research into common failure modes has resulted in a product that rivals the world's best. High quality materials, high temperature electronic components and special contact material will provide years of reliable operation.

### **FEATURES:**

- UV stable, high impact acrylic dome
- AgSnO<sub>2</sub> contact material (high current switching capability)
- Shielded phototransistor (sensor does not stare at the sun)
- Automated assembly (no internal lead wires)
- Near hermetic sealing (prevents moisture ingress)
- Low heat rise
- Extremely rigid NEMA contacts
- Satisfies SABS 1777 (2004)
- Weighs 100g

The units can be supplied with a NEMA socket if required.

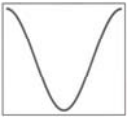

# COSINE DEVELOPMENTS

“LEADERS IN LIGHTING TECHNOLOGY”

## SPECIFICATIONS:

Satisfies

SANS 1777 (2004)

SANS 1777:2004	Requirement	Tested
<b>General</b>		
Operating ambient temperature	-15 <sup>0</sup> C to +60 <sup>0</sup> C	
Orientation	Omni-directional	
Environmental stability	Resistance to ageing	UV stabilised?
<b>Mechanical Strength</b>		
PECU shape	Conical or spherical	Conical
Base connections	NEMA or 20mm screw	NEMA
Degree of protection	IP65	IP65
Impact strength	> 0.5 Nm	
<b>Electrical</b>		
Mains voltage	230Vrms +/- 10%	230Vrms +/- 10%
Insulation resistance	500Vdc	
Dielectric strength		
Surge arrestor	required	
Contact rating	1800VA for 1000 cycles	
Insulation system	Class E (120 <sup>0</sup> C)	
PECU failure mode	“ON” or closed	Failure in “on” position
Creepage and clearances	SANS 60598-1 Sect.11	
<b>Photometric performance</b>		
Switch “on” level	60 lux +/- 12 lux	
Switch “off” level	< 1.5 x switch “on” level	
Switching delay	>15 seconds	
Durability after 1000 cycles	Within 5%	
<b>Durability and marking</b>		
15s with water and hexane	No curing or peeling	
<b>Resistance to heat</b>		
Base insulating material	SANS 60598-1sect.13.2.1	
<b>Resistance to heat and fire</b>		
Base material shall resist fire	SANS 60598-1sect.13.3.2	

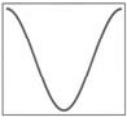

## 6.2 DN2..DN2-L Day/Night switch – CFL loading



The DN-2 Photocell is a compact/rugged daylight switch that can operate both compact fluorescent lamps and incandescent lamps. The unit has a long, tapered sensor tube which makes it easy to install into light fittings. Two 3mm mounting holes are also provided. The unit features a high degree of lightning protection to provide many years of trouble free operation. The DN2-L version has the sensor connected by a fly lead.

### **SPECIFICATIONS:**

Mains voltage	230 Vac
Switching light levels	on = 30 lux: off = 100 lux
Lamp types:	any fluorescent lamp up to 100 Watts and 100 W max incandescent
Size (L x W x H)	53 x 30 x 22 mm
Weight	40g
Maximum operating temperature	70°C

### **INSTALLATION:**

- Drill a 9mm hole in the side of the luminaire for the sensor to detect natural light.
- Direct sunlight must not shine into the sensor. Point the sensor downwards to prevent rainwater or direct sunlight from entering the sensor.
- Seal the aperture with silicon glue.
- The sensor must not detect reflected light from the luminaire (nearby walls etc.).
- The sensor should protrude 5mm outside the luminaire.

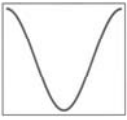

## 6.3 DN-3 Day/Night switch – 125W loading

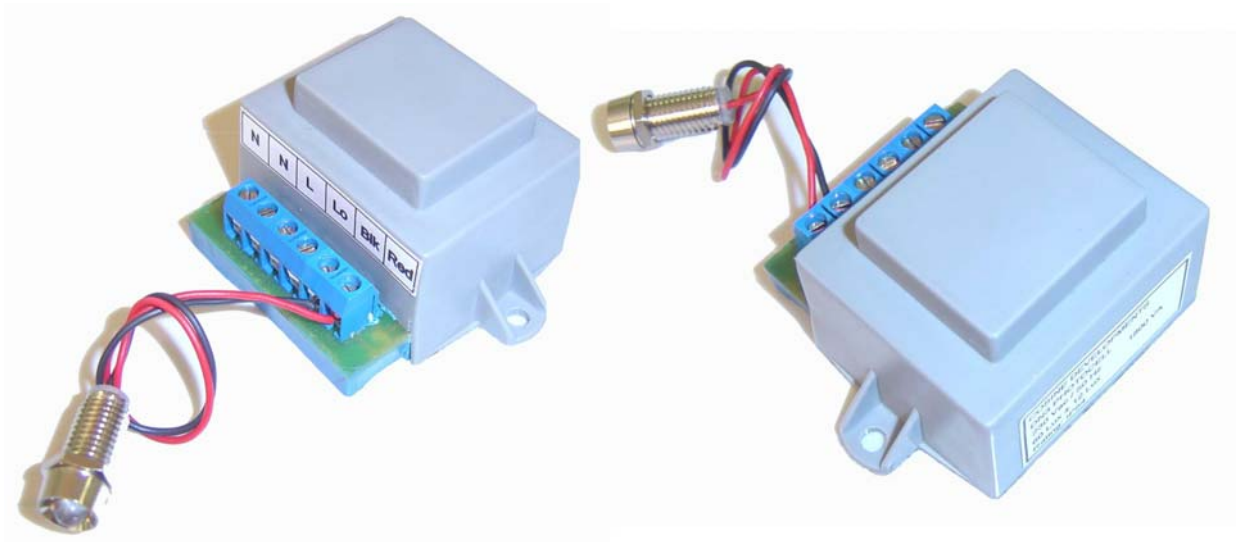

The DN-3 Photocell is a compact/rugged daylight switch that can operate a range of lamps. The unit is housed in a plastic housing with bayonet type terminations which makes it easy to install into light fittings. The switch operates a range of HID lamps including fluorescent and incandescent lamps. The day/night sensor is connected by a fly lead to the screw connector of the module.

Types of lamps that are can be operated from the DN-3 are:-

- MV (Mercury vapour)
- HPS (High Pressure Sodium)
- Metal Halide
- Fluorescent
- Incandescent

### **SPECIFICATIONS:**

Mains voltage	230 Vac
Rating	1800VA
Switching light levels	60 lux $\pm$ 12lux
Lamp types:	MV (Mercury vapour) up to 125W HPS (High Pressure Sodium) up to 125W Metal Halide lamps up to 125W
Size (L x W x H)	53 x 45 x 34 mm
Weight	93g
Maximum operating temperature	+70 °C

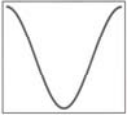

## **INSTALLATION:**

- Drill a 8mm hole in the side of the luminaire for the sensor to detect natural light.
- Direct sunlight must not shine into the sensor. Point the sensor downwards to prevent rainwater or direct sunlight from entering the sensor.
- Seal the aperture with silicon glue.
- The sensor must not detect reflected light from the luminaire (nearby walls *etc.*).
- The sensor should protrude 5mm outside the luminaire.

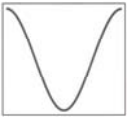

## 6.4 INFRA-RED AUTOLIGHT *Occupancy Sensor for Energy Saving*



- Unsurpassed relay contact rating of 30A
- Saves Energy from 25-75%
- Monitors Occupants movements
- Switches Fluorescent lights on & off
- PIR or Ultra Sonic or both
- Bank switching

### Introduction

The **COSINE DEVELOPMENTS** occupancy energy management systems are motion-sensing devices that automatically turn on and off fluorescent luminaries. They save energy by turning off lights when areas are not in use. Case studies have shown energy savings from 25-75%.

An appropriate application for an occupancy sensor is in a space that is used infrequently or unpredictably, such as a:

- Conference Room
- Private Office
- Storage Area
- Restroom

Although the system can be used in any area, occupancy sensors should be a part of any companies lighting system, mainly because many offices are left unoccupied for a significant amount of time each day, typically with the lights on. Reducing this load will result in measurable savings. If the company does not "sweep" lights off during night-time hours, weekends and holidays, the sensor will ensure that the lights are off when the space is unoccupied.

It is probable that more energy savings will be derived from having the lighting system turned off by sensors at these times than will be realized during normal working hours.

The occupancy sensor is an energy-saving control device that turns lights on and off depending on the occupancy of the space being controlled.

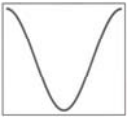

# COSINE DEVELOPMENTS

“LEADERS IN LIGHTING TECHNOLOGY”

When people are in the room, the lights are enabled on, and when the room is vacated for a set period of time (usually 15 minutes) the device turns off the lights.

This provides energy savings ranging from 25 percent to 50 percent, depending on the habits of the occupants of the space.

When electric lighting controls are used properly, energy will be saved and the life of lamps and ballasts can be extended. Lighting controls will help reduce energy by:

- Reducing the amount of power used during the peak demand period by automatically turning them off when they are not needed
- Reducing the number of hours per year that the lights are on

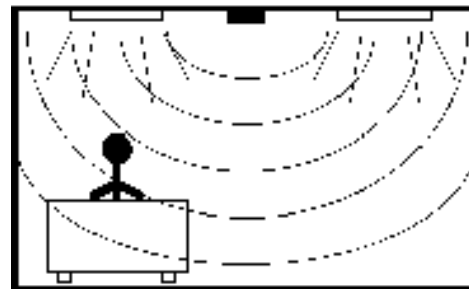
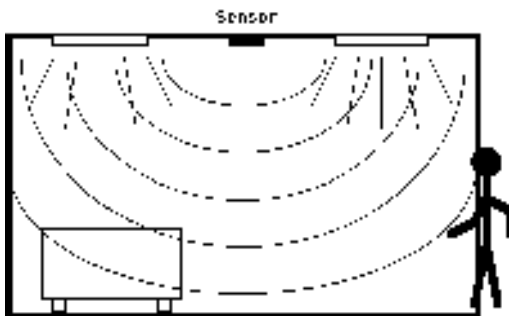
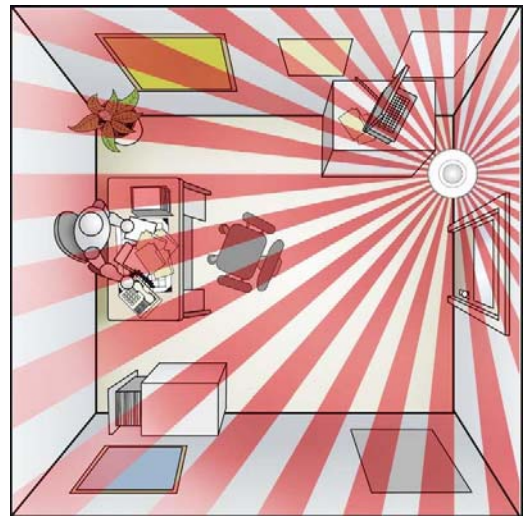

Companies must account for false triggering of sensors, which could occur when someone walks past the door of a controlled room and is "picked up" by the sensor, or when a sensor turns off lights in an occupied room where the occupant has remained still for the sensor's shutoff time period.

When adjusting occupancy sensors, particular attention should be given to patterns of usage in the space. In general, "pass-through" areas such as stairwells should be programmed with shorter delays, while frequently used areas should use longer delays to avoid nuisance on/off

## **SPECIFICATIONS:**

Nominal Input voltage	220Vac
Time delay	min (5sec); max (30 min)
Rated load	(55 x 36 Watt T8 lamps) 2kW
Power consumption	0.45(static 0.1W)
Detection speed	0.6 – 1.5m/s
Detection angle	360°
Maximum load	(suitable for bank switching) 30A
Ambient light	<3 lux - daylight
Working temp	10°C - 32°C
Installation height	>3m
Weight	202g
Switch function	Auto/off/manual override
Detection range	15m

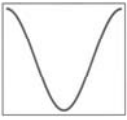

## 6.5 Microwave sensor – FX- MV360S2



The FX-MV360S2 is an active motion detector, it emits a high frequency electro-magnetic wave of 5.8GHz and receives the doppler echo. The sensor detects the change in the doppler echo even from the slightest movement in the detection zone. The unit is designed to fit into the luminaires.

There are no blind spots.

Detection is possible through doors, panes of glass and thin walls and soft furnishings.

### **SPECIFICATIONS:**

Power source	220 – 240Vac
Power frequency	50 – 60 Hz
HF system	5.8GHz CW radar – ISM band
Time delay	8 sec – 12 minutes
Detection angle	360°
Light control	30 lux ccw – daylight (300 lux at 75% cw)
Rated load	600W
Power consumption	0.9W
Weight	67g
Reach	1 – 8 meters
Transmission power	<10mW

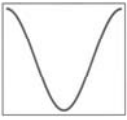

## 7.1

## **BOLLARD** *Emergency control unit with standby feature*



The BOLLARD emergency unit was specifically designed for garden or security lights. All it needs is to be connected to a standard 230Vac outlet (2 wire). The unit will automatically illuminate when it is dark.

The unit will operate in the case of mains or emergency and the photo electric cell will switch the bollard on according to light levels.

The unit is equipped with a 12V 7 Ahr maintenance free sealed lead acid battery which will operate a single 4 pin 18W compact fluorescent lamp at 100% illumination up to 6 hours . The green LED indicates that mains is on and the red LED indicates that the battery is charging, the red LED will go off once the battery is fully charged. If the unit is disconnected from mains for storage then the battery must be disconnected to prevent battery damage.

### **SPECIFICATIONS:**

Mains voltage	230 Vac +/- 10%
Mains power consumption	9VA
Emergency lighting duration	6 hours
Lamp type	4 pin 9W - 18W CFL
Changeover time (High Risk Task Area Lighting)	< 100 ms
Battery protection fuse	10 A
Battery type	12V 7Ahr sealed lead acid
Dimensions (W x H)	220 x 1000 mm
Maximum ambient temperature	+40°C

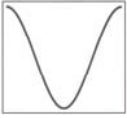

## 8.1

## LED RANGE *LED emergency lighting*



The LED lighting range is available in a wide beam and a narrow beam luminaire. The LED lighting range can operate off both 12 Volts and 220 Volts which makes it ideal for emergency lighting applications.

The narrow beam luminaire can be used for focus lighting and the wide beam can be used for security lighting.

TYPE	Illuminance at 1m	Luminous Flux (Total Lumens)	Viewing angle	Color Temp
26W CFL	542 Lux	1800 lumens	Approx 90 deg	3000 deg K
9W Wide LED	500 Lux	392	Approx 52 deg	9500 deg K
10W Narrow LED	500 Lux	112	Approx 30 deg	7000 - 9000 deg K
20W Narrow LED with lens	1280	241	Approx 43 x 17 deg	9500 deg K

### SPECIFICATIONS:

Mains voltage	230 Vac +/- 10%
AC output	12Vac
Mains power consumption	9 – 20VA
Lamp type	9W, 10W, 20W
Maximum ambient temperature	+70°C

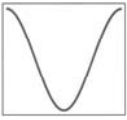

## 9.1

## SOLAR RANGE *solar powered lighting*



The **SOLAR RANGE** provides all night lighting (8 hours) after a full day's exposure to the sun. It has a powerful polychristaline cell structure that ensures optimum battery charging throughout the day, with its high quality 7 Ahr sealed lead acid battery.

The solar panel must be orientated towards the midday sun.

The unit includes a bulk-head, regulator and a 12V sealed lead acid battery with a photocell for day night switching.

The solar lighting system has been developed to provide a reliable light source where no mains powers is available.

### SPECIFICATIONS

DC output	Nominal 12Vdc
Lamp type	9W
Battery type	12V 7Ahr lead acid
Battery Voltage cutout	10.5V
Light fitting	Bulkhead(tough acrylic lens and ABS body)
Day/night lux levels	Night(on) < 200 lux Day(off) > 600 lux
Maximum ambient temperature	+70°C

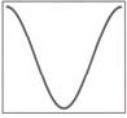

# **COSINE DEVELOPMENTS**

**"LEADERS IN LIGHTING TECHNOLOGY"**

---

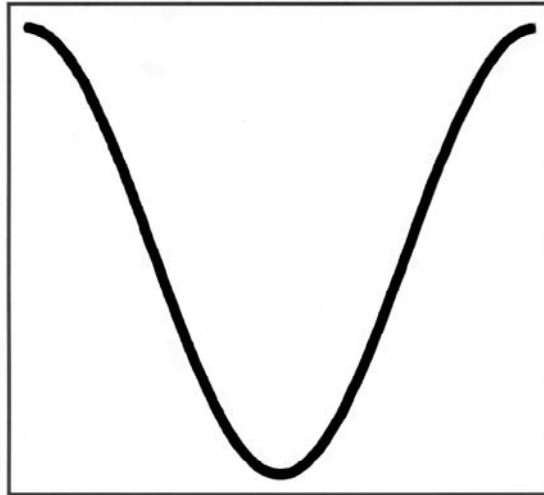

**COSINE DEVELOPMENTS**  
**LEADERS IN LIGHTING TECHNOLOGY**

## **ALL ENQUIRIES**



24 Ashfield Avenue, Springfield Park, Durban, South Africa  
Telephone: +27 31 5792172/3/5 Fax: +27 31 5792176  
PO Box 10177, Marine Parade, 4056, South Africa  
e-mail : [admin@cosine.co.za](mailto:admin@cosine.co.za) / Web site : [www.cosine.co.za](http://www.cosine.co.za)

Due to continuous product improvement colour, sizes, materials, finishes and specifications are subject to change without notice. Consult manufacturer for latest specifications. All manufacturing rights reserved. This document is for information only and shall not form part of any contract.